



Installation Guide

# EV Charging Single Phase Inverter

with SetApp Configuration

For North America

Version 1.1

# Disclaimers

## Important Notice

Copyright © SolarEdge Inc. All rights reserved.

No part of this document may be reproduced, stored in a retrieval system or transmitted, in any form or by any means, electronic, mechanical, photographic, magnetic or otherwise, without the prior written permission of SolarEdge Inc.

The material furnished in this document is believed to be accurate and reliable.

However, SolarEdge assumes no responsibility for the use of this material. SolarEdge reserves the right to make changes to the material at any time and without notice. You may refer to the SolarEdge web site (<https://www.solaredge.com/us/>) for the most updated version.

All company and brand products and service names are trademarks or registered trademarks of their respective holders.

Patent marking notice: see <https://www.solaredge.com/us/patent>

The general terms and conditions of delivery of SolarEdge shall apply.

The content of these documents is continually reviewed and amended, where necessary. However, discrepancies cannot be excluded. No guarantee is made for the completeness of these documents.

The images contained in this document are for illustrative purposes only and may vary depending on product models.

## FCC Compliance

This equipment has been tested and found to comply with the limits for a Class B digital device, pursuant to part 15 of the FCC Rules.

These limits are designed to provide reasonable protection against harmful interference in a residential installation. This equipment generates, uses and can radiate radio frequency energy and, if not installed and used in accordance with the instructions, may cause harmful interference to radio communications. However, there is no guarantee that interference will not occur in a particular installation. If this equipment does cause harmful interference to radio or television reception, which can be determined by turning the equipment off and on, you are encouraged to try to correct the interference by one or more of the following measures:

- Reorient or relocate the receiving antenna.
- Increase the separation between the equipment and the receiver.

- Connect the equipment into an outlet on a circuit different from that to which the receiver is connected.
- Consult the dealer or an experienced radio/TV technician for help.

Changes or modifications not expressly approved by the party responsible for compliance may void the user's authority to operate the equipment.

## Support and Contact Information

If you have technical problems concerning SolarEdge products, please contact us:

USA and Canada: 1 510 498 3200

Worldwide: +972 073 2403118

Fax: +1 (530) 273-2769

Email: [ussupport@solaredge.com](mailto:ussupport@solaredge.com).

Support Center: <https://www.solaredge.com/us/service/support>

Before contact, make sure to have the following information at hand:

- Model and serial number of the product in question.
- The error indicated on the Inverter SetApp mobile application or on the monitoring platform or by the LEDs, if there is such an indication.
- System configuration information, including the type and number of modules connected and the number and length of strings.
- The communication method to the SolarEdge server, if the site is connected.
- The inverter software version as appears in the status screen.

## Revision History

- Version 1.1, May 2019 - editorial changes
- Version 1.0 , April 2019 - first release

## Contents

---

Disclaimers .....	1
Important Notice .....	1
FCC Compliance .....	1
<b>Support and Contact Information .....</b>	<b>3</b>
<b>HANDLING AND SAFETY INSTRUCTIONS .....</b>	<b>7</b>
Safety Symbols Information .....	7
<b>IMPORTANT SAFETY INSTRUCTIONS .....</b>	<b>8</b>
<b>Chapter 1: Introducing the SolarEdge Power Harvesting System .....</b>	<b>13</b>
Power Optimizer .....	14
EV Charging Single Phase Inverter .....	14
Monitoring Platform .....	15
Supported AC Grids .....	15
Installation Procedure .....	17
Installation Equipment List .....	17
Inverter Transport and Storage .....	18
EV Charging Safety Instructions .....	19
<b>Chapter 2: Installing the Power Optimizers .....</b>	<b>20</b>
Safety .....	20
Package Contents .....	22
Installation Guidelines .....	22
Step 1: Mounting and Grounding the Power Optimizers .....	24
Step 3: Connecting Power Optimizers in Strings .....	27
Step 4: Verifying Proper Power Optimizer Connection .....	28
<b>Chapter 3: Installing the Inverter .....</b>	<b>30</b>
Inverter Package Contents .....	30
Identifying the Inverter .....	30
Inverter Interfaces .....	30
Opening Conduit Drill Guides .....	33
Mounting the Inverter .....	35
<b>Chapter 3: Connecting the AC and the Strings to the Connection Unit with Safety Switch .....</b>	<b>38</b>
Grid Connection Guidelines .....	38
Connecting the AC Grid to the Connection Unit with Safety Switch .....	39
Connecting the Strings to the Connection Unit with Safety Switch .....	39
<b>Chapter 4: Activating, Commissioning and Configuring the System .....</b>	<b>42</b>
Step 1: Activating the Installation .....	42
Step 2: Commissioning and Configuring the Installation .....	43

---

Step 3: Verifying Proper Activation and Commissioning .....	47
Viewing System Status .....	48
Reporting and Monitoring Installation Data .....	55
<b>Chapter 5: Setting Up Communication to the Monitoring Platform .....</b>	<b>58</b>
Communication Options .....	58
Communication Connectors .....	60
Removing the Inverter Cover .....	61
Removing the Connection Unit with Safety Switch Cover .....	61
Creating an Ethernet (LAN) Connection .....	63
Creating an RS485 Bus Connection .....	66
Verifying the Connection .....	68
<b>Chapter 5: Errors and Troubleshooting .....</b>	<b>70</b>
Identifying Errors .....	70
EV Charger-related Troubleshooting .....	71
Power Optimizer Troubleshooting .....	74
<b>Mechanical Specifications .....</b>	<b>76</b>
<b>Appendix A: Replacing and Adding System Components .....</b>	<b>77</b>
Fuse Replacement .....	77
Replacing an Inverter .....	78
Replacing the Connection Unit with Safety Switch .....	80
<b>Appendix B: Connecting an External Meter to an Inverter .....</b>	<b>83</b>
Connecting an External Meter to an Inverter .....	83
Connecting an External Meter to an Inverter with a Built in Revenue Grade Meter (RGM) .....	83
<b>Technical Specifications - EV Charging Single Phase Inverter (North America) 84</b>	
Inverter Specifications .....	84
Default Trip Limits and Times According to IEEE1547 .....	86
Recommended OCPD Size per Grid .....	87
EV Charger and EV Charger Cable Specifications .....	87

# HANDLING AND SAFETY INSTRUCTIONS

During installation, testing and inspection, adherence to all the handling and safety instructions is mandatory. **Failure to do so may result in injury or loss of life and damage to the equipment.**

## Safety Symbols Information

The following safety symbols are used in this document. Familiarize yourself with the symbols and their meaning before installing or operating the system.

### WARNING!

Denotes a hazard. It calls attention to a procedure that, if not correctly performed or adhered to, could result in **injury or loss of life**. Do not proceed beyond a warning note until the indicated conditions are fully understood and met.



### AVERTISSEMENT!

*Dénote un risque: il attire l'attention sur une opération qui, si elle n'est pas faite ou suivie correctement, pourrait causer des blessures ou un danger de mort. Ne pas dépasser une telle note avant que les conditions requises soient totalement comprises et accomplies.*

### CAUTION!

Denotes a hazard. It calls attention to a procedure that, if not correctly performed or adhered to, could result in **damage or destruction of the product**. Do not proceed beyond a caution sign until the indicated conditions are fully understood and met.



### ATTENTION!

*Dénote un risque: il attire l'attention sur une opération qui, si elle n'est pas faite ou suivie correctement, pourrait causer un dommage ou destruction de l'équipement. Ne pas dépasser une telle note avant que les conditions requises soient totalement comprises et accomplies.*



### NOTE

Denotes additional information about the current subject.



### IMPORTANT SAFETY FEATURE

Denotes information about safety issues.



## IMPORTANT SAFETY INSTRUCTIONS

SAVE THESE INSTRUCTIONS

## CONSIGNES DE SÉCURITÉ IMPORTANTES

CONSERVEZ CES INSTRUCTIONS

### WARNING!

When using electric products, basic precautions should always be followed, including the following. This manual contains important instructions that shall be followed during installation, operation and maintenance of the unit.

- a. Read all the instructions before using this product.
- b. This device should be supervised when used around children.
- c. Do not put fingers into the electric vehicle connector.
- d. Do not use this product if the flexible power cord or EV cable is frayed, has broken insulation, or any other signs of damage.



- e. Do not use this product if the enclosure or the EV connector is broken, cracked, open, or shows any other indication of damage.
1. An insulated grounding conductor that is identical in size, insulation material, and thickness to the grounded and ungrounded branch-circuit supply conductors, except that it is green with or without one or more yellow stripes, shall be installed as part of the branch circuit that supplies the device or system.
  2. The grounding conductor described in item 1 shall be grounded to earth at the service equipment or, when supplied by a separately derived system, at the supply transformer.

### AVERTISSEMENT!

*Des mesures de précautions de base devraient être utilisées avec tous les produits électriques, y compris les mesures indiquées ici. Ce manuel contient d'importantes instructions à suivre au moment de l'installation, de l'utilisation et de l'entretien de l'appareil.*

- a. Lire toutes les instructions avant d'utiliser ce produit.
- b. Ce dispositif ne devrait pas être laissé sans surveillance s'il est utilisé près d'enfants.
- c. Ne pas mettre les doigts dans la prise du véhicule électrique.
- d. Ne pas utiliser ce produit si le cordon souple ou le câble VE est effiloché, si

*l'isolant est endommagé, ou s'il présente tout autre signe d'endommagement.*

- e. *Ne pas utiliser ce produit si le boîtier ou la prise EV est endommagé, fissuré, ouvert, ou s'il présente tout autre signe d'endommagement.*
1. *Un conducteur de mise à la terre isolé dont les dimensions, le matériau d'isolation et l'épaisseur sont identiques aux conducteurs d'alimentation de circuit de dérivation mis à la terre et non mis à la terre, sauf qu'il est vert avec ou sans une ou plusieurs bandes jaunes circuit qui alimente l'appareil ou le système.*
2. *Le conducteur de mise à la terre décrit à l'article 1 doit être relié à la terre à l'équipement de service ou, lorsqu'il est alimenté par un système dérivé séparément, au transformateur d'alimentation.*

#### WARNING!



The inverter cover must be opened only after switching the inverter ON/OFF/P switch located at the bottom of the inverter to OFF. This disables the DC voltage inside the inverter. Wait five minutes before opening the cover. Otherwise, there is a risk of electric shock from energy stored in the capacitors.

#### AVERTISSEMENT!

*Ne pas ouvrir le couvercle de l'onduleur avant d'avoir coupé l'interrupteur situé en dessous de l'onduleur. Cela supprime les tensions CC et CA de l'onduleur. Attendre cinq minutes avant d'ouvrir le couvercle. Sinon, il y a un risque de choc électrique provenant de l'énergie stockée dans le condensateur.*

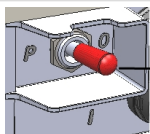

ON/OFF/P Switch:  
0 = OFF  
1 = ON  
P = Pairing

#### WARNING!



Before operating the inverter, ensure that the inverter is grounded properly. This product must be connected to a grounded, metal, permanent wiring system, or an equipment-grounding conductor must be run with the circuit conductors and connected to the equipment grounding terminal or lead on the product.

#### AVERTISSEMENT!

*Avant d'utiliser l'onduleur monophasé, assurez-vous que l'onduleur est correctement mis à la terre. Ce produit doit être raccordé à un système de câblage fixe, métallique, l'équipement-le conducteur de mise à la terre doit être exécuté avec les conducteurs de circuit et raccordé à l'équipement borne de mise à la terre ou de plomb sur le produit.*

**WARNING!**

Opening the inverter and repairing or testing under power must be performed only by qualified service personnel familiar with this inverter.

**AVERTISSEMENT!**

*L'unité ne doit être ouverte que par un technicien qualifié dans le cadre de l'installation et de la maintenance.*

**WARNING!**

The Safety Switch meets all requirements for a code-compliant installation of this system. The DC Disconnect Switch disconnects both the positive and negative conductors.

**AVERTISSEMENT!**

*Le sectionneur externe (inclus) répond aux exigences de conformité pour l'installation de ce système. Le coupeur CC ouvre les conducteurs positifs et négatifs.*

**WARNING!**

The inverter input and output circuits are isolated from the enclosure. This system does not include an isolation transformer and should be installed with an ungrounded PV array in accordance with the requirements of NEC Articles 690.35 and 690.43 National Electric Code, ANSI/NFPA 70, 2011 (and Canadian Electrical Code, Part I, for installations in Canada).

Equipment grounding is the responsibility of the installer and must be performed in accordance with all applicable Local and National Codes.

**AVERTISSEMENT!**

*Les circuits d'entrée et de sortie de l'onduleur sont isolés de l'enveloppe. Ce système n'inclut pas d'isolation galvanique (transformateur) et devra être installé sans mise à la terre du champ PV et en accord avec les articles 690.35 et 690.43 du National Electric Code (NEC), ANSI/NFPA 70, 2011 (et du Code Electrique Canadien, Partie 1, pour les installations faites au Canada). La mise à la terre des équipements est la responsabilité de l'installateur et doit être faite en accord avec toutes les règles locales et nationales applicables.*

**WARNING!**

The inverter must be connected to a dedicated AC branch circuit with a maximum Overcurrent Protection Device (OCPD) of 50A.

The SE10000H-US and SE11400H-US must be connected to a dedicated AC branch circuit with a maximum Overcurrent Protection Device (OCPD) of 80A.

**AVERTISSEMENT!**

*Les onduleurs doivent être connectés à un branchement AC dédié avec un disjoncteur de 50A.*

*Les onduleurs SE10000H-US et SE11400H-US doivent être connectés à un branchement AC dédié avec un disjoncteur de 80A*

**WARNING!**

SolarEdge products can expose you to chemicals including antimony trioxide, which is known to the State of California to cause cancer. For more information, go to [www.P65Warnings.ca.gov](http://www.P65Warnings.ca.gov).

**AVERTISSEMENT!**

*Les produits SolarEdge peut vous exposer à des agents chimiques, y compris trioxyde d'antimoine, identifiés par l'État de Californie comme pouvant causer le cancer. Pour de plus amples informations, prière de consulter [www.P65Warnings.ca.gov](http://www.P65Warnings.ca.gov).*

**CAUTION!**

This unit must be operated according to the technical specification datasheet provided with the unit.

**ATTENTION!**

*Cette unité doit être utilisée selon les spécifications de fonctionnement, comme décrit dans la dernière fiche technique des spécifications.*

**CAUTION!**

HEAVY OBJECT. To avoid muscle strain or back injury, use proper lifting techniques, and if required - a lifting aid.

**ATTENTION!**

*Objet lourd. Pour éviter la fatigue musculaire ou des blessures au dos, utilisez des techniques de levage appropriées et, si nécessaire - un auxiliaire de levage lors du retrait.*

**NOTE**

Use only copper conductors rated for a minimum of 75°C/ 167°F.

**NOTE**

This inverter is provided with an IMI (Isolation Monitor Interrupter) for ground fault protection.

**NOTE**

The symbol  appears at grounding points on the SolarEdge equipment. This symbol is also used in this manual.

NOTE

A SolarEdge inverter may be installed in a site with a generator. SolarEdge requires installing a physical or electronic interlock, which will signal to the inverter when the grid has been disconnected. Interlock procurement, installation, maintenance and support are the responsibility of the installer.



Damage to the inverter due to incorrect interlock installation or use of an interlock that is incompatible with the SolarEdge system will render the SolarEdge warranty invalid.

For more information, refer to

<https://www.solaredge.com/sites/default/files/se-inverter-support-of-voltage-sources.pdf>.



# Chapter 1: Introducing the SolarEdge Power Harvesting System

The SolarEdge power harvesting solution maximizes the power output from any type of solar Photovoltaic (PV) installation while reducing the average cost per watt. The following sections describe each of the system's components.

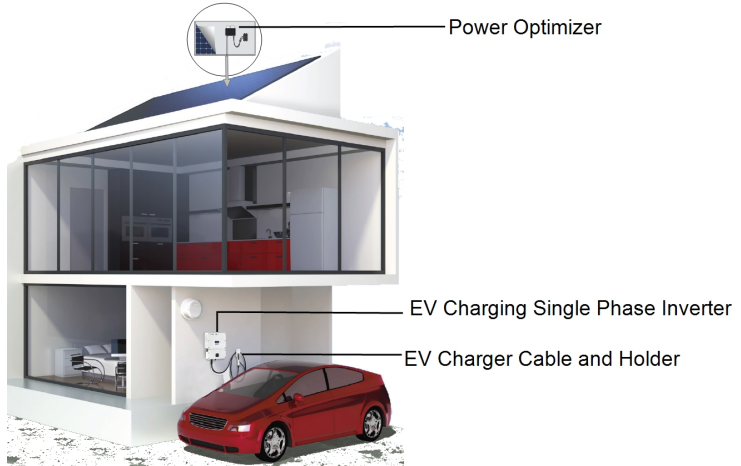

Figure 1: The SolarEdge power harvesting system components

## Power Optimizer

The power optimizers are DC-DC converters connected to PV modules in order to maximize power harvesting by performing independent Maximum Power Point Tracking (MPPT) at the module level.

The power optimizers regulate the string voltage at a constant level, regardless of string length and environmental conditions.

The power optimizers include a safety voltage function that automatically reduces the output of each power optimizer to 1 Vdc in the following cases:

- During fault conditions
- The power optimizers are disconnected from the inverter
- The inverter ON/OFF/P switch is turned OFF
- The inverter AC breaker is turned OFF
- The Rapid Shutdown (PVRSS) is initiated by one of the following methods:
  - Inverter AC breaker is turned OFF, or AC to the inverter is disconnected by another method (intentionally or as result of a fault)
  - Inverter ON/OFF/P switch is turned OFF
  - The Connection Unit with Safety Switch is turned OFF

Each power optimizer also transmits module performance data over the DC power line to the inverter.

Two types of power optimizers are available:

- Module Add-on power optimizer – connected to one or more modules
- Smart modules - the power optimizer is embedded into a module

## EV Charging Single Phase Inverter

The EV Charging Single Phase Inverter (referred to as “inverter” throughout) efficiently converts DC power from the modules into AC power that can be fed into the main AC service of the site and from there to the grid. The inverter also receives the monitoring data from each power optimizer and transmits it to a central server (the monitoring platform; requires Internet connection).

The EV Charging Single Phase Inverter is designed to provide reliable and economical charging of an electric vehicle (EV). It provides Level 2 EV charging from both the grid and the PV system, and is designed to work with all plug-in vehicles with J1772 (Type 1) socket.

An EV Charger cable (ordered separately) is required for EV charging:

- The EV Charger Cable connects the EV plug to the inverter
- The wall mounted EV Charger cable holder is used for hanging the EV Charger cable and plug, protecting the plug from rain when not plugged into the vehicle (V2 holders), and provides strain relief for the inverter when the cable is pulled.

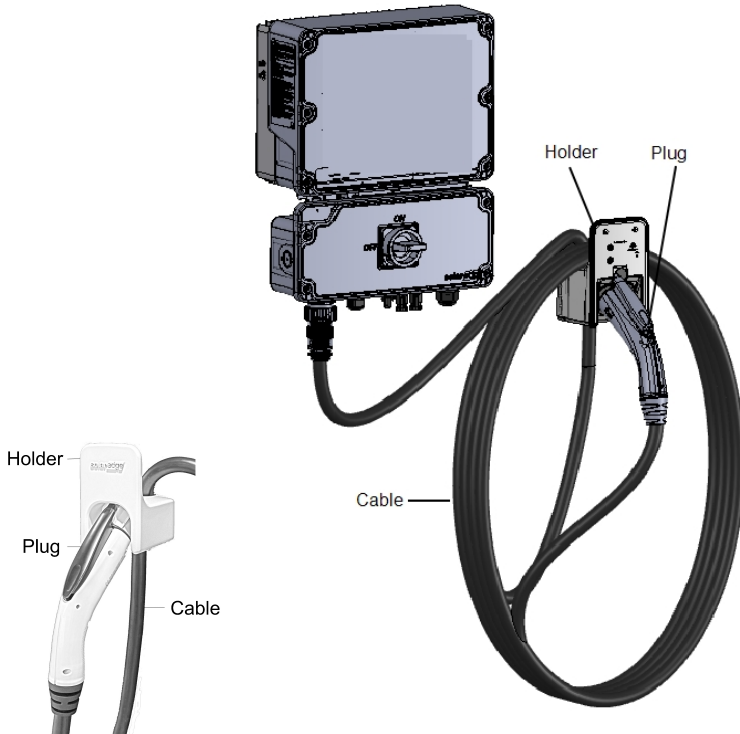

Figure 2: The EV Charger Cables (with holders)

## Monitoring Platform

The monitoring platform enables monitoring the technical and financial performance of one or more SolarEdge sites. It provides past and present information on the system performance both at the system and module levels.

## Supported AC Grids

The following figures illustrate grids that are supported by SolarEdge single phase inverters. Refer to *Setting Country and Language* on page 44 ).



Ground connection is required for all grids, as described in *Connecting the AC Grid to the Connection Unit with Safety Switch* on page 39.

Note that in some cases L1 and L2 are not interchangeable. In these places, L1 and L2 locations appear in the drawing.

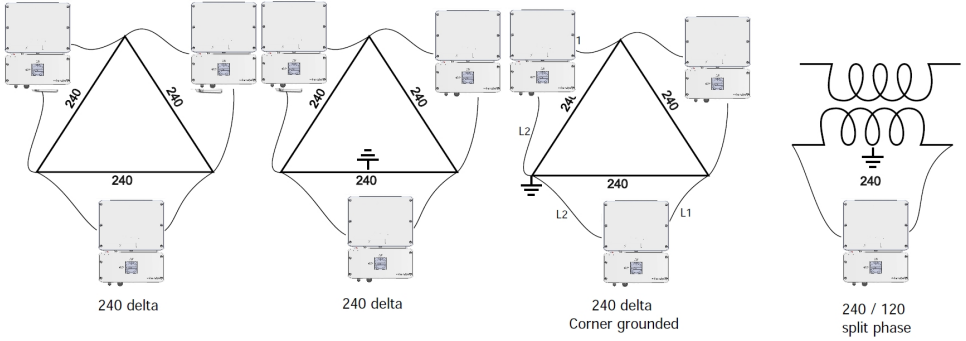

Figure 3: 240V AC grids supported by SolarEdge single phase inverter

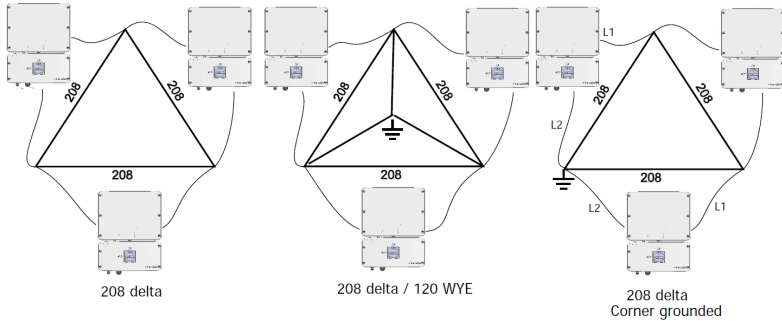

Figure 4: 208V AC grids supported by SolarEdge single phase inverter<sup>(1)</sup>

(1) 208V AC grids are only supported by some inverter models. Refer to the specification supplied with the inverter.

## Installation Procedure

The following is the procedure for installing and setting up a new SolarEdge site. Many of these also apply to modification of an existing site.

1. [Connecting Power Optimizers in Strings](#), page 27.
2. [Recording power optimizer serial numbers \(optional\)](#), page 56.
3. [Mounting the inverter](#), page 35.
4. [Connecting AC and Strings to the Safety Switch](#) page 38.
5. [Activating, Commissioning and Configuring the System Using the Inverter SetApp](#), page 42
6. [Connecting the inverter to the monitoring platform](#), page 57.
7. Installing and connecting the cable - Refer to the installation guide supplied with the product. The cable and holder can be installed at the same time as the inverter or added later.
8. Configuring the EV Charger - Refer to the installation guide supplied with the EV Charger Cable. Configuration can be done only after the EV Charger Cable is connected to the inverter and the inverter is connected to the monitoring platform.

## Installation Equipment List

Standard tools can be used during the installation of the SolarEdge system. The following is a recommendation of the equipment needed for installation:

- Allen screwdriver for 3mm screw type for the inverter cover, side screws, and Safety Switch cover
- Standard flat-head screwdrivers set
- Non-contact voltage detector
- Cordless drill (with a torque clutch) or screwdriver and bits suitable for the surface on which the inverter and optimizers will be installed and for opening the Connection Unit with Safety Switch drill guides. Use of an impact driver is *not* allowed.
- Appropriate mounting hardware (for example: stainless bolts, nuts, and washers) for attaching:
  - the inverter mounting bracket to the mounting surface
  - the power optimizer to the racking (not required for smart modules)
- Wire cutters

- Wire strippers
- Voltmeter
- Mobile phone with latest SetApp version

For installing the communication options, you may also need the following:

- For Ethernet:
  - CAT5/6 twisted pair Ethernet cable with RJ45 connector
  - If using a CAT5/6 cable spool: RJ45 plug and RJ45 crimper
- For RS485:
  - Four- or six-wire shielded twisted pair cable
  - Watchmaker precision screwdriver set

## **Inverter Transport and Storage**

Transport the inverter in its original packaging, facing up and without exposing it to unnecessary shocks. If the original package is no longer available, use a similar box that can withstand the weight of the inverter (refer to the inverter weight in the specification datasheet provided with the unit), has a handle system and can be closed fully.

Store the inverter in a dry place where ambient temperatures are -13°F to 140°F / -25°C to +60°C.

## EV Charging Safety Instructions

**WARNING!**

Do not charge a vehicle indoors if it requires ventilation. Contact your EV service representative for information.

**AVERTISSEMENT!**

*Ne pas recharger un véhicule à l'intérieur si il nécessite une ventilation. Contactez votre représentant de service pour plus d'informations.*

**WARNING!**

Automatic CCID (charge circuit interrupting device) reset provided.

**AVERTISSEMENT!**

*Réinitialisation CCID (charge circuit interrupting device) automatique incluse.*

**WARNING!**

Risk of electric shock. Do not remove cover. No user serviceable parts inside. Refer servicing to qualified service personnel.

**AVERTISSEMENT!**

*Risque de choc électrique. Ne pas retirer le couvercle. Pas de pièces sujettes à maintenance. Laissez la maintenance à du personnel qualifié.*

**CAUTION!**

Do not use this product if there is any damage to the unit.

**ATTENTION!**

*Ne pas utiliser pas ce produit si l'appareil est endommagé.*

**CAUTION!**

Do not use an extension cord between the SolarEdge EV Charger Cable and the EV Charging Single Phase Inverter. You may use a conversion adapter only if it has been approved by SolarEdge.

**NOTE**

This product is intended for use with electric vehicles, however it operates as a PV inverter also when no charging cable is connected.

## Chapter 2: Installing the Power Optimizers

### Safety

The following notes and warnings apply when installing the power optimizers. Some of the following may not be applicable to smart modules:

#### WARNING!



The metallic enclosure of the power optimizer must be grounded in accordance with the product's listing and local and national codes.

#### AVERTISSEMENT!

*L'enceinte métallique de l'optimiseur de puissance doit être mise à la terre en accord avec les réglementations locales et nationales.*

#### WARNING!



When modifying an existing installation, turn OFF the inverter ON/OFF/P switch, the Safety Switch and the AC circuit breaker on the main AC distribution panel.

#### AVERTISSEMENT!

*Avant de faire ces étapes, éteignez l'onduleur monophasé en mettant sur OFF l'interrupteur ON/OFF/P situé au bas de l'onduleur.*

#### CAUTION!



Power optimizers are IP68/NEMA6P rated. Choose a mounting location where optimizers will not be submerged in water.

#### ATTENTION!

*Les optimiseurs de puissances sont compatibles à la norme IP68/NEMA6P. Choisissez le lieu de montage tel que l'optimiseur ne puisse pas être submergé par l'eau.*

#### CAUTION!



This unit must be operated according to the operating specifications provided with the unit.

#### ATTENTION!

*Cette unité doit être opérée suivant les instructions trouvées dans le manuel fourni avec le produit.*

#### CAUTION!



Cutting the power optimizer input or output cable connector is prohibited and will void the warranty.

#### ATTENTION!

*Sectionner les câbles d'entrées ou de sortie de l'optimiseur est interdit et annule*

sa garantie.

**CAUTION!**

All PV modules must be connected to a power optimizer.

**ATTENTION!**

Tous les modules doivent être connectés à un optimiseur de puissance.

**CAUTION!**

If you intend to mount the optimizers directly to the module or module frame, first consult the module manufacturer for guidance regarding the mounting location and the impact, if any, on module warranty. Drilling holes in the module frame should be done according to the module manufacturer instructions.

**ATTENTION!**

*Pour installation à même le module ou la monture du module, consultez d'abord le fabricant du module sur la position et son impact sur la garantie du module. Le perçage de trous dans le cadre du module devra se faire suivant les instructions du fabricant.*

**CAUTION!**

Installing a SolarEdge system without ensuring compatibility of the module connectors with the optimizer connectors may be unsafe and could cause functionality problems such as ground faults, resulting in inverter shut down. To ensure mechanical compatibility of the power optimizers' connectors with the PV modules' connectors to which they are connected:

- Use identical connectors from the same manufacturer and of the same type on both the power optimizers and on the modules; or
- Verify that the connectors are compatible in the following way:
  - The module connector manufacturer should explicitly verify compatibility with the SolarEdge optimizer connector; and
  - A third-party test report by one of the listed external labs (TUV, VDE, Bureau Veritas UL, CSA, InterTek) should be obtained, verifying the compatibility of the connectors.



For more information, refer to

<https://www.solaredge.com/sites/default/files/optimizer-input-connector-compatibility.pdf>



**ATTENTION!**

Les connecteurs du module doivent être mécaniquement compatibles avec les optimiseurs de puissance. Sinon, le système SolarEdge installé peut être dangereux ou causer des problèmes fonctionnels, tels que les défauts de terre, qui peuvent provoquer un arrêt de l'onduleur. Afin d'assurer la compatibilité mécanique entre les optimiseurs de puissance SolarEdge et les modules auxquels ils sont connectés:

- Utiliser des connecteurs identiques du même fabricant et du même type aussi bien pour les optimiseurs de puissance que pour les modules.
- Vérifiez que les connecteurs sont compatibles de la manière suivante:
  - Le fabricant du connecteur doit explicitement vérifier la compatibilité avec le connecteur SolarEdge.
  - Un rapport de test de tierce partie doit être effectué par l'un des laboratoires externes indiqués ci-dessous:(TUV, VDE, Bureau Veritas UL, CSA,Intertek), qui vérifiera la compatibilité des connecteurs.



Pour plus d'informations, consultez

<https://www.solaredge.com/sites/default/files/optimizer-input-connector-compatibility.pdf>

**IMPORTANT SAFETY FEATURE**

Modules with SolarEdge power optimizers are safe. They carry only a low safety voltage before the inverter is turned ON. As long as the power optimizers are not connected to the inverter or the inverter is turned OFF, each power optimizer will output a safe voltage of 1V.

## Package Contents

- Power optimizers
- Stainless steel grounding lock washers

## Installation Guidelines

- The minimum and maximum string length guidelines are stated in the power optimizer datasheets. Refer to the Designer for string length verification. The Designer is available on the SolarEdge website at <https://www.solaredge.com/us/products/installer-tools/designer#/>.

- Frame-mounted power optimizers are mounted directly on the module frame, regardless of racking system (rail-less or with rails). For installation of frame-mounted power optimizers, refer to [http://www.solaredge.com/sites/default/files/installing\\_frame\\_mounted\\_power\\_optimizers.pdf](http://www.solaredge.com/sites/default/files/installing_frame_mounted_power_optimizers.pdf).
- The power optimizer can be placed in any orientation.
- If connecting more modules than optimizer inputs in parallel, use a branch cable. Some commercial power optimizer models have a dual input.
- Position the power optimizer close enough to its module so that their cables can be connected.
- Make sure to use power optimizers that have the required output conductor length:
  - *Do not* use extension cables between a module and a power optimizer, between two modules connected to the same optimizer, or between two optimizers other than in the cases specified below.
  - You can use extension cables between power optimizers only from row to row, around obstacles or pathways within a row, and from the end of the string to the inverter, as long as the maximum distance is not exceeded.

**NOTE**

- Use at least 11 AWG/ 4 mm<sup>2</sup> DC cables.
- The total cable length of the string (excluding power optimizers' cables) should not exceed 1000ft./300 m from DC+ to DC- of the inverter.

- Completely shaded modules may cause their power optimizers to temporarily shut down. This will not affect the performance of the other power optimizers in the string, as long as the minimum number of unshaded power optimizers connected in a string of modules is met. If under typical conditions fewer than the minimum optimizers are connected to unshaded modules, add more optimizers to the string.
- Equipment grounding tightening torques: 4-6 AWG: 45 lb-in, 8 AWG: 40 lb-in, 10-14 AWG: 35 lb-in.
- To allow for heat dissipation, maintain a minimum of 2.5 cm / 1" clearance between the power optimizer and other surfaces, on all sides except the mounting bracket side.



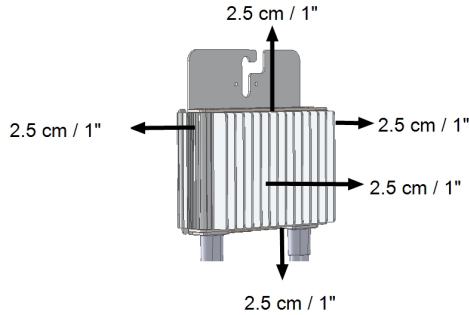

Figure 5: Power optimizer clearance

- When installing modules in a confined space, for example, if installing Building-integrated photovoltaic (BIPV) modules, ventilation measures may be needed to ensure the power optimizers are not be exposed to temperatures outside their specifications.

**NOTE**

The images contained herein are for illustrative purposes only and may vary depending on product models.

## Step 1: Mounting and Grounding the Power Optimizers

For each of the power optimizers<sup>(1)</sup>:

- Determine the power optimizer mounting location and use the power optimizer mounting brackets to attach the power optimizer to the support structure (See *Figure 6*). It is recommended to mount the power optimizer in a location protected from direct sunlight. For frame-mounted power optimizers follow the instructions supplied with the optimizers, or refer to [https://www.solaredge.com/sites/default/files/installing\\_frame\\_mounted\\_power\\_optimizers.pdf](https://www.solaredge.com/sites/default/files/installing_frame_mounted_power_optimizers.pdf).
- If required, mark the mounting hole locations and drill the hole.



<sup>(1)</sup>Not applicable to smart modules.

**CAUTION!**

Drilling vibrations may damage the power optimizer and will void the warranty. Use a torque wrench or an electric drill with adjustable clutch that meets the mounting torque requirements. *Do not* use impact drivers for mounting the power optimizer.

*Do not* drill through the power optimizer or through the mounting holes.

**ATTENTION!**

*Les vibrations résultant du perçage peuvent endommager l'optimiseur de puissance et annulera la garantie. Utilisez une clé dynamométrique ou une perceuse électrique avec embrayage adaptable compatible avec les moments indiqués. Ne pas utiliser des tournevis à percussion pour fixer l'optimiseur. Ne pas percer à travers l'optimiseur de puissance ou ses trous de fixation.*

3. Attach each power optimizer to the rack using M6 (1/4") stainless steel bolts, nuts and washers or other appropriate mounting hardware. Apply torque of 9-10 N\*m / 6.5-7 lb\*ft.

For 3NA series power optimizers, SolarEdge recommends mounting the power optimizer on a rail with the smooth side facing out, so that the power optimizer body will prevent its rotation.

4. Use the following methods<sup>(1)</sup> to ground the power optimizer:

**WARNING!**

The metallic enclosure of the power optimizer must be grounded in accordance with the requirements of the local and national codes.

**AVERTISSEMENT!**

*L'enceinte métallique de l'optimiseur de puissance doit être mise à la terre en accord avec les réglementations locales et nationales.*

---

<sup>(1)</sup>These methods have been evaluated by a nationally recognized testing laboratory as part of the optimizer evaluation. The SolarEdge-supplied grounding lug kit has been evaluated only for use with SolarEdge power optimizers. It is not intended or listed to be used as a general purpose grounding lug with other electrical equipment.

- For mounting on a grounded metal rail:** Use the provided 5/16" stainless steel grounding star washer between the railing and the flat side of the mounting bracket. The grounding washer should break through the anodize coating of the railing to ensure low resistive connection. Apply a torque of 9.5 N\*m / 7 lb\*ft.

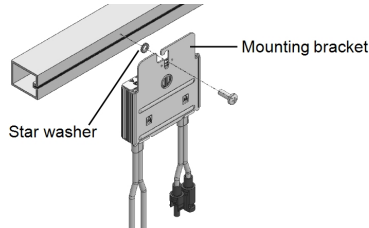

Figure 6: Power optimizer installation and grounding using a star washer

- For mounting on rails with sliding nut fasteners:** If the star washer cannot be used, use the SolarEdge grounding plate (purchased separately) between the railing and the flat side of the mounting bracket. Use mounting specific hardware as needed. Apply torque of 9.5 N\*m / 7 lb\*ft. See *Figure 7*.

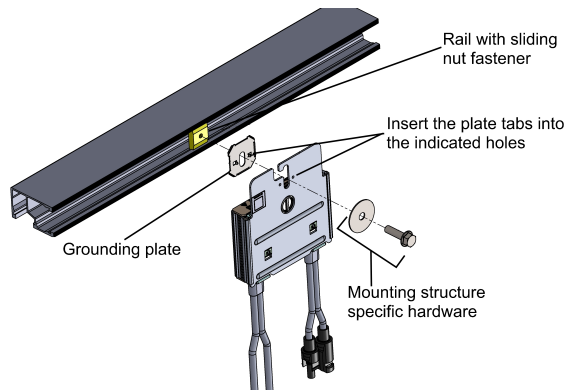

Figure 7: Power optimizer installation and grounding using a grounding plate

- For mounting on un-grounded structures** (such as a wooden structure): If the star washer or the plate cannot be used, use the SolarEdge grounding lug (purchased separately) with an equipment-grounding conductor according to the supplied instructions. The grounding terminal accepts a wire size of 6-14 AWG, and must be sized for equipment grounding per NEC 250.122 requirements. Tighten the screws connecting the power optimizer to the frame and the grounding terminal screw. Apply torque of 9.5 N\*m / 7 lb\*ft. See *Figure 8*.

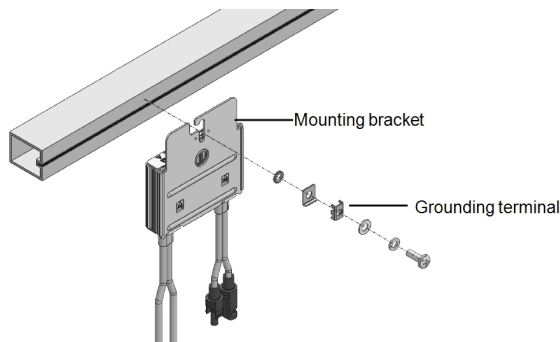

Figure 8: Power optimizer grounding terminal

5. Verify that each power optimizer is securely attached to the module support structure.
6. Record power optimizer serial numbers and locations, as described in *Reporting and Monitoring Installation Data* on page 55.

### Step 3: Connecting Power Optimizers in Strings

You can construct parallel strings of unequal length, that is, the number of power optimizers in each string does not have to be the same. The minimum and maximum string lengths are specified in the power optimizer datasheets. Refer to the [Designer](#) for string length verification.



1. Connect the Minus (-) output connector of the string's first power optimizer to the Plus (+) output connector of the string's second power optimizer.
2. Connect the rest of the power optimizers in the string in the same manner.

#### WARNING!



If using a dual-input power optimizer and some inputs are not used, seal the unused input connectors with the supplied pair of seals.

#### AVERTISSEMENT!

*Si un optimiseur à double entrées est utilisé et que certaines entrées ne sont pas connectées, fermez ces entrées avec la paire de couvercles fournie.*

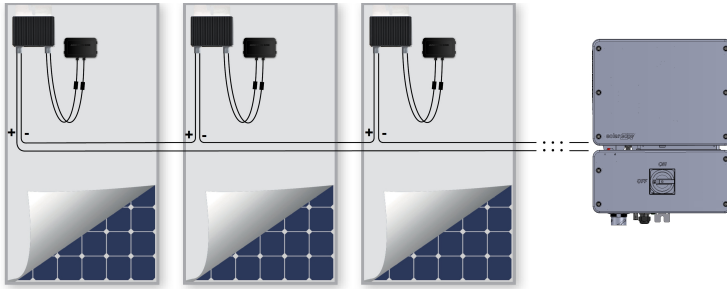

Figure 9: Power optimizers connected in series

3. If you intend to monitor the installation, using the monitoring platform, record the physical location of each power optimizer, as described in *Creating Logical and Physical Layout using Installation Information* on page 56.

## Step 4: Verifying Proper Power Optimizer Connection

When a module is connected to a power optimizer, the power optimizer outputs a safe voltage of 1V ( $\pm 0.1V$ ). Therefore, the total string voltage should equal 1V times the number of power optimizers connected in series in the string. For example, if 10 power optimizers are connected in a string, then 10V should be produced.

Make sure the PV modules are exposed to sunlight during this process. The power optimizer will only turn ON if the PV module provides at least 2W.

In SolarEdge systems, due to the introduction of power optimizers between the PV modules and the inverter, the short circuit current  $I_{SC}$  and the open circuit voltage  $V_{OC}$  hold different meanings from those in traditional systems.

For more information about the SolarEdge system's string voltage and current, refer to the  $V_{OC}$  and  $I_{SC}$  in *SolarEdge Systems Technical Note*, available on the SolarEdge website at:

[https://www.solaredge.com/sites/default/files/isc\\_and\\_voc\\_in\\_solaredge\\_systems\\_technical\\_note.pdf](https://www.solaredge.com/sites/default/files/isc_and_voc_in_solaredge_systems_technical_note.pdf).



### → To verify proper power optimizer connection:

Measure the voltage of each string individually before connecting it to the other strings or to the inverter. Verify correct polarity by measuring the string polarity with a voltmeter. Use a voltmeter with at least 0.1V measurement accuracy.

#### NOTE



Since the inverter is not yet operating, you may measure the string voltage and verify correct polarity on the DC wires inside the Connection Unit with Safety Switch.

For troubleshooting power optimizer operation problems, refer to *Power Optimizer Troubleshooting* on page 74.

## Chapter 3: Installing the Inverter

Install the inverter either before or after the modules and power optimizers have been installed.



### NOTE

Use only copper conductors rated for a minimum of 75°C/ 167°F.

## Inverter Package Contents

- One inverter with Connection Unit with Safety Switch
- Mounting bracket kit
- Connection Unit with Safety Switch sealing cover (if applicable, for use in case of inverter replacement)
- Installation guide
- Antenna and mounting bracket for wireless communication (in specific models)

## Identifying the Inverter

Refer to the sticker on the inverter that specifies its **Serial Number** and its **Electrical Ratings**. Provide the serial number when contacting SolarEdge support. The serial number is also required when opening a new site in the monitoring platform.

## Inverter Interfaces

The following figures show the inverter and Connection Unit with Safety Switch connectors and interfaces.

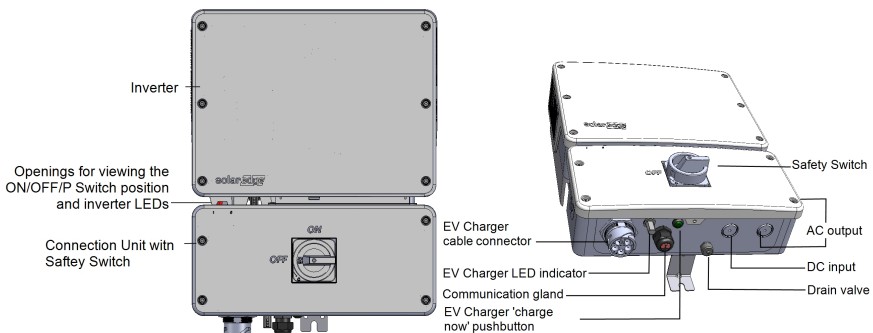

Figure 10: Inverter and Connection Unit with Safety Switch interfaces

## Connection Unit with Safety Switch Interface

- **EV Charger cable connector:** Used for connecting the EV charger cable to the inverter
- **EV Charger LED indicator:** Three LEDs indicate the EV Charger statuses.

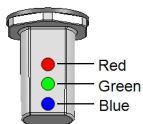

Figure 11: LEDs

The following table lists the LED indications when the EV Charger Cable is connected to the inverter and activated (refer to the EV Charger Cable Installation Guide supplied with the EV Charger Cable):

Color	Description
All LEDs	<b>OFF</b> - No AC power
Red	<b>ON</b> - Error
Blue	<b>ON</b> - the EV Charger is communicating with the inverter <b>OFF</b> - the EV Charger is not communicating with the inverter
Green	<b>ON</b> - Charging <b>Blinking</b> <sup>(1)</sup> - the EV Charger is plugged in but not charging <b>Flickering</b> <sup>(2)</sup> - the EV Charger is ready to charge but not plugged in

- **AC output / input :** For connection of the AC grid
- **DC input :** For connection of the PV installation
- **Communication gland:** For connection of inverter communication options. Refer to *Setting Up Communication to the Monitoring Platform* on page 58 for more information.

(1)Lights ON for 1000mS and OFF for 1000mS

(2)Lights ON for 100mS and OFF for 5000mS



- **EV Charger pushbutton:** Pressing the button on the Connection Unit with Safety Switch has the following functionality:
  - For a system with scheduled charging: Start charging immediately (not during charging scheduled times). For setting a charging schedule, refer to the EV Charger Cable Installation Guide (supplied with the EV Charger Cable).
  - In case of an error ,the system re-tests after 15 minutes. Pressing the pushbutton performs the re-test immediately.
- **Drain valve:** Drains any moisture that may be accumulated in the unit.

## Inverter Interface

- **ON/OFF/P switch:** Turning this switch ON starts the operation of the power optimizers, enables power production and allows the inverter to begin exporting power to the utility grid. Turning it OFF reduces the power optimizer voltage to a low safety voltage and inhibits exportation of power. When this switch is OFF, the inverter control circuitry remains powered up.
- **Inverter LED indicator** (See *Figure 11*) : Indicate the inverter statuses as described in the following table:

Color	Description	Functionality
All LEDs turn on while the inverter is being configured.		
Green	Power production	<p><b>On</b> - The inverter is producing power.</p> <p><b>Blinking</b> - Standby mode. The inverter is in Standby mode until its working voltage is reached. The inverter then enters Production mode and produces power.</p> <p><b>Off</b> - The inverter is not producing power. This may be during Night mode, when the inverter ON/OFF/P switch is OFF or when an error occurs.</p>
Blue	Communication and inverter shutdown	<p><b>Blinking:</b></p> <ul style="list-style-type: none"> <li>- Monitoring information is being received from a power optimizer.</li> <li>-The inverter is being shut down.</li> </ul>
Red	Error	<p><b>On</b> - There is an error. Refer to <i>Errors and Troubleshooting</i> on page 70 for more information.</p> <p><b>Blinking</b> - The inverter is being shut down.</p>

## DIP Switches

Set the circuit breaker rating DIP switches (see *Figure 12*).

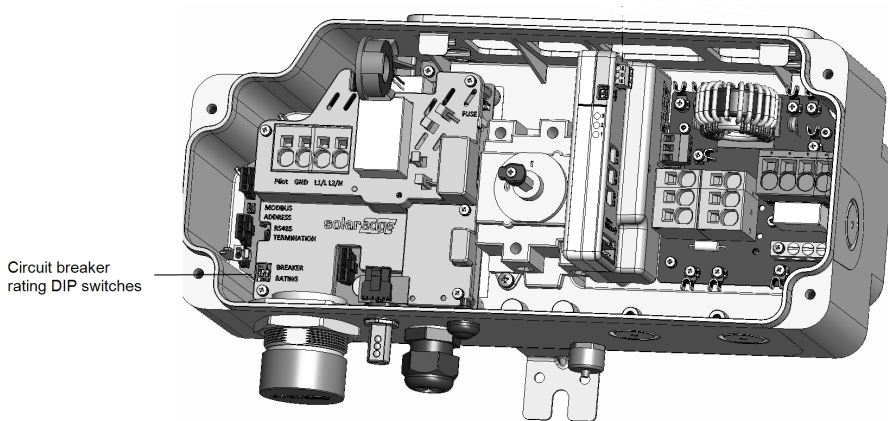

Figure 12: Safety Switch with EV Charger internal interfaces

→ To set the circuit breaker ratings:

Use the circuit breaker rating DIP switches to set circuit breaker ratings.

Circuit Breaker Rating	DIP Switch Settings		Maximum Allowed AC Current from Grid
	1 (left)	2 (right)	
20 A	OFF	OFF	16 A
30 A	ON	OFF	24 A
40 A	OFF	ON	32A
50 A	ON	ON	40 A

## Buzzer

The EV charger includes a buzzer with the following indications:

Event	Buzzer Indication
Connected to EV	1 short beep
Charging starts	2 short beeps + 1 long beep
Error	5 beeps

## Opening Conduit Drill Guides

This step may be performed before or after mounting the inverter.

→ To open conduit drill guides:

1. Move the Connection Unit with Safety Switch ON/OFF/P switch and the inverter ON/OFF/P switch to OFF.
2. Loosen the screws on the front cover of the Connection Unit with Safety Switch, as shown below:

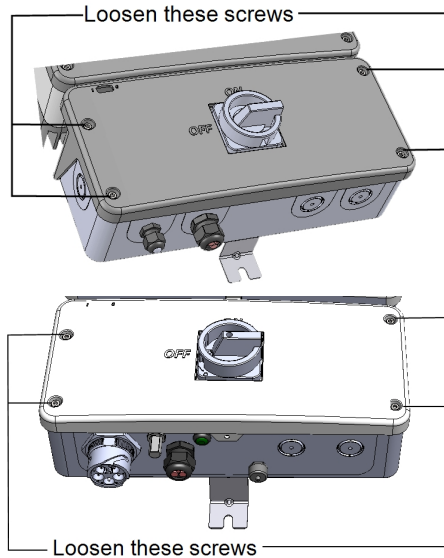

Figure 13: Opening the Connection Unit with Safety Switch cover

3. Remove the Connection Unit with Safety Switch cover.
4. Open the required AC and DC conduit drill guides according to the conduits used in the installation: The drill guides are located at the bottom and sides of the enclosure, each with two sizes:  $\frac{3}{4}$ " and 1". Open the required drill guides, taking care not to interfere with any of the internal components. It is recommended to use a Unibit drill.

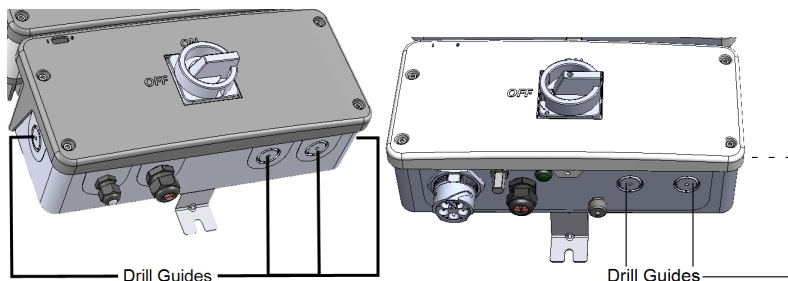

Figure 14: Connection Unit with Safety Switch drill guides



**NOTE**  
Unused conduit openings and glands should be sealed with appropriate seals.

## Mounting the Inverter

The inverter is supplied with a mounting bracket kit:

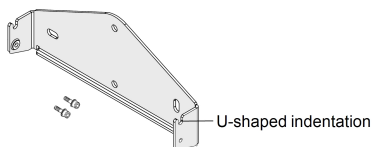

Figure 15: Mounting bracket



**NOTE**  
Make sure the mounting surface or structure can support the weight of the inverter.



**CAUTION!**  
SolarEdge inverters and power optimizers can be installed at a minimum distance of 50 m/ 164 ft from the shoreline of an ocean or other saline environment, as long as there are no direct salt water splashes on the inverter or power optimizer.

**ATTENTION!**  
*Les onduleurs SolarEdge peuvent être installés à une distance minimum de 50m de la ligne d'eau de l'océan ou autre environnement salin, tant qu'il n'y a pas d'éclaboussements d'eau salée directs sur l'onduleur.*

1. Determine the inverter mounting location, on a wall, stud framing or pole. It is recommended to mount the inverter in a location protected from direct sunlight.
2. To allow proper heat dissipation, maintain the following minimum clearance areas

between the inverter and other objects:

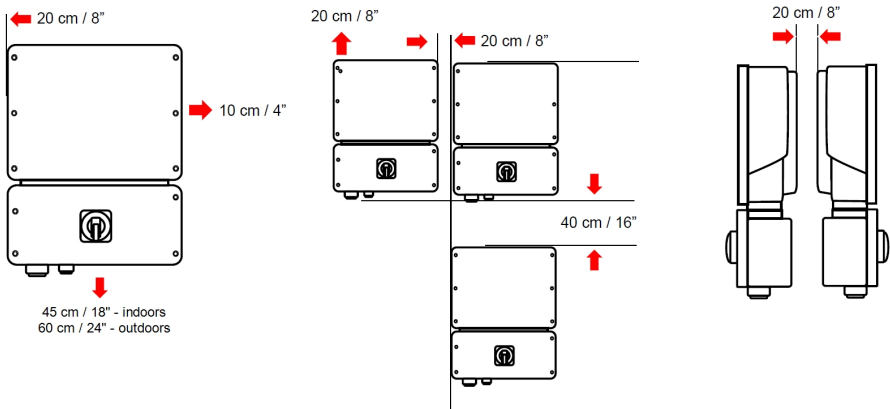

Figure 16: Clearance areas

- 8" (20 cm) from the top of the inverter.
  - At least 18" (45 cm) from the bottom of the inverter if installing it indoors, 24" (60 cm) if outdoors; if conduit entry to the Connection Unit with Safety Switch will be from the bottom, leave sufficient clearance for the conduits as well.
  - 4" (10 cm) from the right and left of the inverter.
3. Position the mounting bracket against the wall/ pole and mark the drilling hole locations (refer to *Mechanical Specifications* on page 76 for inverter and mounting bracket dimensions).
  4. Drill the holes and mount the bracket. Verify that the bracket is firmly attached to the mounting surface.
  5. Hang the inverter on the bracket:
    - a. Lift the inverter from the sides, or hold it at the top and bottom of the inverter to lift the unit into place. Do not lift holding the Safety Switch as it may be damaged.
    - b. Lower the inverter onto the U-shaped indentations, as shown below. Let the inverter lay flat against the wall or pole.
    - c. Insert the two supplied screws through the outer heat sink fin on both sides of the inverter and into the bracket. Tighten the screws with a torque of 4.0 N\*m / 2.9 lb.\*ft.

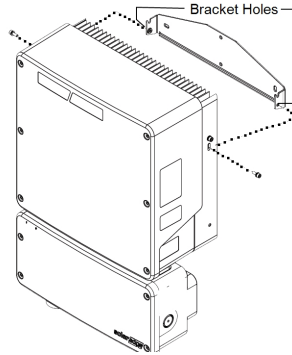

Figure 17: Hanging the inverter on the brackets

6. Optionally, secure the Connection Unit with Safety Switch bracket to the wall/pole, using 3 screws:



**NOTE**

In case of inverter replacement with the Connection Unit with Safety Switch still mounted, it is recommended to use all 3 holes.

- a. Mark the location of the bracket screw for the Connection Unit with Safety Switch, and optionally the two additional bracket holes.

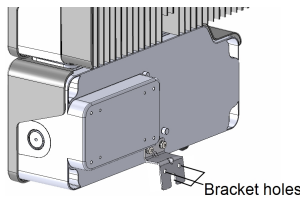

Figure 18: Connection Unit with Safety Switch bracket

- b. Remove the inverter from the wall/ pole.
  - c. Drill the hole for the Connection Unit with Safety Switch bracket.
  - d. Hang the inverter on the mounted brackets.
  - e. Fasten the Connection Unit with Safety Switch bracket using a standard bolt.
7. Insert the screws at the top of the inverter brackets and fasten the brackets together.
  8. Verify that all the brackets are firmly attached to the mounting surface.

## Chapter 3: Connecting the AC and the Strings to the Connection Unit with Safety Switch

The Connection Unit with Safety Switch disconnects all ungrounded DC conductors of the circuit to which it is connected in compliance with the National Electric Code, and specifically NEC690.3, which addresses ungrounded PV arrays. The Connection Unit with Safety Switch is rated to the maximum operating conditions of the inverter.

The following figure illustrates the Connection Unit with Safety Switch.

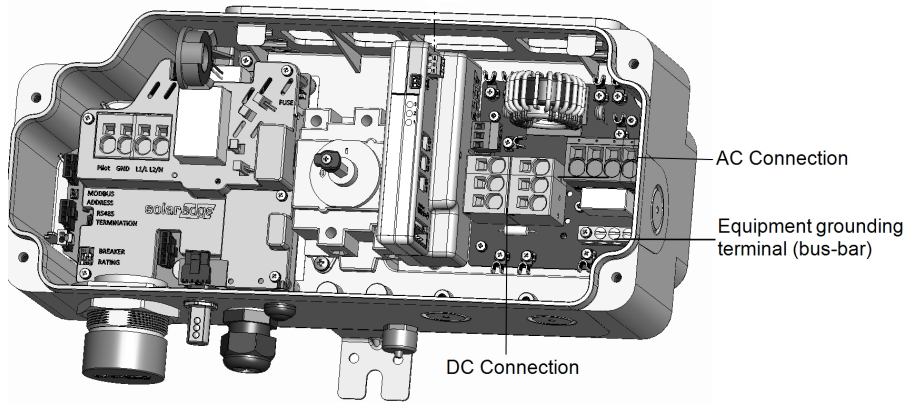

Figure 19: Inside the Connection Unit with Safety Switch

### Grid Connection Guidelines

- In single phase inverters connected to corner grounded grids, connect the L2 terminal to the grounded conductor. When connecting to other grids, L1 and L2 are interchangeable.
- The conduits, hubs and fittings must be suited for field wiring systems.
- The hubs and other fittings must comply with UL514B.
- Use the conduit and wiring appropriate for the installation location per the NEC. Outdoor installations must use components that are rated NEMA 3R or higher.

## NOTE



For more wiring information refer to the *SolarEdge Recommended AC Wiring Application Note*, available on the SolarEdge website at

<https://www.solaredge.com/sites/default/files/application-note-recommended-wiring.pdf>



## Connecting the AC Grid to the Connection Unit with Safety Switch

1. Strip 5/16" (8mm) of the AC wire insulation.
2. Insert the AC conduit into the AC-side drill guide that was opened.

## NOTE



Connect the equipment grounding before connecting the AC wires to the AC terminal block.

*Veillez à relier le conducteur de PE (la terre) avant de connecter les fils CA au bornier CA.*

3. Connect the wires to the appropriate terminal blocks according to the labels on the terminal blocks (N, , L1 and L2).
4. Use a standard flat-blade screwdriver to connect the wires to the spring-clamp terminals. The screwdriver blade should fit freely in the terminal opening. Too large a blade can crack the plastic housing.
  - a. Insert the screwdriver and press the release mechanism and open the clamp.
  - b. Insert the wire into the round opening and remove the screwdriver – the wire is automatically clamped.
5. Verify that there are no unconnected wires.
6. If additional grounding wires need to be connected, use the equipment grounding bus-bar. Tighten using a torque of 3.4 N\*M / 30 lb-in.

## Connecting the Strings to the Connection Unit with Safety Switch

You can connect systems with multiple DC strings in parallel to the DC input terminals of the Connection Unit with Safety Switch. Inverters may have a different number of pairs of DC input terminals, depending on the inverter power rating. If more strings are required, they can be connected in parallel using an external combiner box before connecting to the Connection Unit with Safety Switch. When connecting multiple



strings, it is recommended to run separate circuits to the Connection Unit with Safety Switch or to position the combiner box near the Connection Unit with Safety Switch. This simplifies commissioning by allowing testing and servicing near the inverter.

**NOTE**

Use 16-6 AWG, 75-90°C copper wires only.

→ **To connect the strings to the Connection Unit with Safety Switch:**

1. Equipment grounding: Connect the DC equipment ground conductor to the equipment grounding terminal block in the Connection Unit with Safety Switch.

**NOTE**

Functional Electrical Earthing of DC-side negative or positive is prohibited because the inverter has no transformer. Equipment grounding of exposed conductive surfaces in the array is required per the NEC.

2. Insert the DC conduit into the DC-side opening on the Connection Unit with Safety Switch (left side at the bottom of the Connection Unit with Safety Switch).
3. Connect the DC wires to the DC+ and DC- terminal blocks, according to the labels on the terminals, connect two wires (DC+ and DC-) per string:
  - a. Use a standard flat-blade screwdriver to connect the wires to the spring-clamp terminals. The screwdriver blade should fit freely in the terminal opening. Too large a blade can crack the plastic housing.
  - b. Insert the screwdriver and firmly tilt it to press the release mechanism and open the clamp.
  - c. Insert the wire into the top opening.
  - d. Remove the screwdriver – the wire is automatically clamped.

**CAUTION!**

Ensure that the Plus (+) wire is connected to the + terminal and that the Minus (-) wire is connected to the Minus (-) terminal connector.

**ATTENTION!**

*Veillez à ce que le câble Plus (+) soit connecté au terminal + et que le câble - soit connecté au connecteur terminal.*

## NOTE

For systems with four PV strings per unit or more, fuses may need to be installed in both the positive and negative conductors as required by NEC Article 690.9. For more information, refer to the “String Fusing Requirements in SolarEdge Systems” technical note at

[http://www.solaredge.com/files/pdfs/string\\_fusing\\_requirements.pdf](http://www.solaredge.com/files/pdfs/string_fusing_requirements.pdf).



## NOTE

SolarEdge's fixed input voltage architecture enables the parallel strings to be of different lengths. Therefore, they do not need to have the same number of power optimizers, as long as the length of each string is within the permitted range.

4. Close the Connection Unit with Safety Switch cover: Attach the switch cover and secure it by tightening the four screws with a torque of 1.2 N\*m/ 0.9 lb\*ft.
5. Ensure proper conduit sealing; inspect the entire conduit run and use standard conduit sealants to avoid water penetration.

## Chapter 4: Activating, Commissioning and Configuring the System

You can connect communication options at this stage, as described in *Setting Up Communication to the Monitoring Platform* on page 58.

Once all connections are made, the system should be activated and commissioned using the Inverter SetApp mobile application. You can download the app from the Apple App Store and Google Play prior to reaching the site.



Internet connection is required for the download and for the one-time registration, however not required for using the SetApp.

### Step 1: Activating the Installation

During system activation, a Wi-Fi connection is created between the mobile device and the inverter and the system firmware is upgraded.

**Before activation** - download, register (first time only) and log-in to SetApp on your mobile device. Internet connection is required for the download and for the one-time registration. Verify that the application is updated with the latest version.

→ **To activate the inverter:**

1. Turn ON the AC circuit breaker on the main distribution panel.
2. Open SetApp and follow the instructions on the screen (scan the inverter bar-code; move the ON/OFF/P switch to P position and release within 5 sec. back to ON (1) position). SetApp creates a Wi-Fi connection, upgrades the inverter CPU firmware and activates the inverter.

- When the activation is complete, do one of the following:
  - Select **Activate Another Inverter** to continue activating additional inverters.
  - Select **Start Commissioning** for pairing and other system configuration. The Commissioning screen is displayed. Refer to the next section for more information.

## Step 2: Commissioning and Configuring the Installation

This section describes how to use the SetApp menus for commissioning and configuring the inverter settings.

Menus may vary in your application depending on your system type.

→ To access the Commissioning screen:

Do one of the following:

- During first time installation: Upon Activation completion, in the SetApp, tap **Start Commissioning**. The main Commissioning menu screen is displayed.

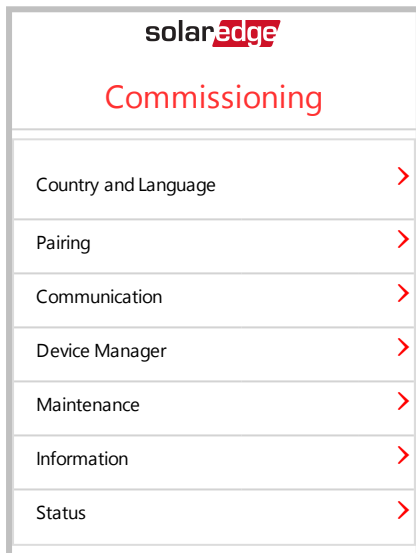

- If the inverter has already been activated and commissioned:

- If not already ON - turn ON AC to the inverter by turning ON the circuit breaker on the main distribution panel.
- Open SetApp and follow the instructions on the screen (scan the inverter bar-code; move the ON/OFF/P switch to P position (for less than 5 sec) and release).

The mobile device creates a Wi-Fi connection with the inverter and displays the main Commissioning screen.

In the main menus, tap the menu red arrows (➤) to perform the system commissioning or configuration task. Tap the **Back** arrow (⏪) to return to the previous menu.

The next sections provide more information about configuration options (in addition to **Country and Language** and **Pairing**, described in *Step 2: Commissioning and Configuring the Installation* on page 43).

## Setting Country and Language

1. From the Commissioning screen select **Country and Language**.
2. From the **Country** drop-down list, select the required country setting.

### WARNING!



The inverter must be configured to the proper setting in order to ensure that it complies with the country grid code and functions properly with the country grids.

### AVERTISSEMENT!

*L'onduleur doit être configuré pour le pays approprié afin d'assurer un fonctionnement convenable avec le réseau de ce pays.*

3. From the **Language** drop-down list, select the language.
4. Tap **Set Language**.

## Pairing

1. From the main menu, select **Pairing**.
2. Tap **Start Pairing**.
3. When **Pairing Complete** is displayed, the system startup process begins:  
Since the inverter is ON, the power optimizers start producing power and the inverter starts converting AC.

**WARNING!**

When you turn ON the inverter ON/OFF/P switch, the DC cables carry a high voltage and the power optimizers no longer output a safe output.

**AVERTISSEMENT!**

*Après avoir mis l'interrupteur ON/OFF/P de l'onduleur monophasé sur ON, les câbles DC portent une haute tension et les optimiseurs de puissance ne génèrent plus la tension de sécurité de .*

When the inverter starts converting power after the initial connection to the AC, the inverter enters Wakeup mode until its working voltage is reached. This mode is indicated by the flickering green inverter LED.

When working voltage is reached, the inverter enters Production mode and produces power. The steadily lit green inverter LED indicates this mode.

4. Tap **OK** to return to the main menu.

## Communication

Communication settings can be configured only after communication connections are complete. Refer to *Setting Up Communication to the Monitoring Platform* on page 58.

1. Select the **Communication** menu to define and configure the following:
  - The communication option used by the inverter to communicate with the monitoring platform.
  - The communication option used to communicate between multiple SolarEdge devices or other external non-SolarEdge devices, such as electricity meters or loggers.
2. Tap the **Server** red arrow to set the communication method to be used for communication between devices and the SolarEdge monitoring platform. The default is LAN.

**NOTE**

The Server menu shows only the communication options installed in the inverter.

For detailed information about all the configuration options, refer to the *Communication Options Application Note*, available on the SolarEdge website at [https://www.solaredge.com/sites/default/files/solaredge-communication\\_options\\_application\\_note\\_v2\\_250\\_and\\_above.pdf](https://www.solaredge.com/sites/default/files/solaredge-communication_options_application_note_v2_250_and_above.pdf).



## Power Control

Power control options are detailed in the *Power Control Application Note*, available on the SolarEdge website at .

The Grid Control option may be disabled. Enabling it opens additional options in the menu.

The Energy Manager option is used for setting power export limitation, as described in the *Export Limitation Application Note*, available on the SolarEdge website at [https://www.solaredge.com/sites/default/files/export\\_limitation\\_application\\_note\\_NA.pdf](https://www.solaredge.com/sites/default/files/export_limitation_application_note_NA.pdf).



For P(Q) diagram refer to [https://www.solaredge.com/sites/default/files/application\\_note\\_p\\_q\\_diagram\\_of\\_se\\_inverters\\_en\\_and\\_na.pdf](https://www.solaredge.com/sites/default/files/application_note_p_q_diagram_of_se_inverters_en_and_na.pdf).



### NOTE



SolarEdge inverters with “Grid Support” functionality (as marked on the inverter certification label), are compliant with UL 1741 Supplement A. The functionality is built into the inverter and no additional external device is required.

## Device Manager

From the **Commissioning** menu, select **Device Manager** to configure various system Smart Energy Management devices.

## Maintenance

From the **Commissioning** menu, select **Maintenance** to configure various system settings, as described below.

- **Date and Time:** Set the internal real-time clock. If connected to the monitoring platform, the date and time are set automatically and only time zone should be set.
- **Reset Counters:** Resets the accumulated energy counters that are sent to the monitoring platform.
- **Factory Reset:** Performs a general reset to the default device settings.
- **Firmware Upgrade:** Perform a software upgrade.

- **Diagnostics:** Displays the Isolation status and power optimizer status screens. Refer to [https://www.solaredge.com/sites/default/files/application\\_note\\_isolation\\_fault\\_troubleshooting.pdf](https://www.solaredge.com/sites/default/files/application_note_isolation_fault_troubleshooting.pdf).
- **Activate Standby Mode:** Enables/disables Standby Mode - for remote commissioning.
- **Grid Protection:** Available in specific countries. Enables viewing and setting grid protection values.
- **Board Replacement:** Backs up and restores the system parameters, including energy counters; Used during board replacement according to the instructions supplied with replacement kits.



## Information

From the **Commissioning** menu, select **Information** to view and set various system settings, as described below.

- **CPU Version:** The communication board firmware version
- **DSP 1/2 Version:** The digital board firmware version



### NOTE

Please have these numbers ready when you contact SolarEdge Support.

- **Serial Number:** The inverter serial number as appears on the enclosure sticker
- **Error Log:** Displays the last five errors, and enables resetting (clearing) the log
- **Warning Log:** Displays the last five warnings, and enables resetting (clearing) the log

## Step 3: Verifying Proper Activation and Commissioning

1. Select **Information** and verify that the correct firmware versions are installed on each inverter.
2. Select **Status** and verify that inverter is operating and producing power (see also *Viewing System Status* on page 48).
3. Verify that additional configurations were properly set by viewing the relevant Status screens.
4. Verify that the green inverter LED is steadily lit.

Your SolarEdge power harvesting system is now operational.



## Viewing System Status

During normal operation, the **Status** screen displays all the inverter settings and operation status. Scroll up or down to display various status parameters as described in the following sections.

The LED indication provides more information about system performance; Refer to *LEDs* on page 31.

→ To access the Status screen:

From the **Commissioning** menu select **Status**. The main inverter Status screen is displayed (see below).

A red or orange icon (for example: ) may appear at the top left corner of a status cell, indicating an error. The color indicates error severity (red is top severity). The error description or information appears on the screen. Tap the error line for more information and troubleshooting instructions, and refer to *Errors and Troubleshooting* on page 70.

A gray clock icon () may appear at the top left corner of a status cell, indicating a temporary status, such as a connection process. When the process is complete, the icon disappears and a constant status message is displayed.

## Main Inverter Status

solar <b>edge</b>		
Status		
<b>Inverter</b>		
SN 07318000C		
<b>Power</b> 7.6 kW	<b>Voltage</b> 240Vac	<b>Frequency</b> 60 Hz
🕒 <b>P_OK: 15 of 30</b> Optimizers Connected	<b>Server Comm.</b> S_OK (LAN)	
<b>Status</b> Production	⚠️ <b>Switch</b> OFF	
<b>CosPhi</b> 1.00	<b>Limit</b> No Limit	<b>Country</b> USA2
<b>Voltage</b> 380 Vdc	<b>Temp</b> 156 F	<b>Fan</b> OK
⚠️ Switch Off. Production disabled >		
<b>Commissioning</b> >		



- **Inverter:** The inverter serial number
- **Power:** The AC output power
- **Voltage (Vac):** The AC output voltage
- **Frequency:** The AC output frequency
- **P\_OK: xxx of yyy:** There is a connection to the power optimizers and at least one power optimizer is sending monitoring data. XXX is the number of power optimizers for which telemetries have been received in the last two hours. YYY is the number of paired power optimizers identified during the most recent pairing process. If XXX and YYY are not equal, there may be a problem in one or more power optimizers.
- **S\_OK:** The connection to the monitoring platform. (**Server Connected** appears only if the inverter is connected to the monitoring platform).





- **Status:** The inverter operation status: Off, Not Paired, Night Mode, Error, Pairing, or Production.
- **Switch:** Indicates the position of the inverter ON/OFF/P switch: On, Off, or P position.
- **CosPhi:** Indicates the ratio between active and reactive power. A negative value indicates a lagging CosPhi.
- For more information, refer to the *Power Control Application Note*, available on the SolarEdge website at [https://www.solaredge.com/sites/default/files/application\\_note\\_power\\_control\\_configuration.pdf](https://www.solaredge.com/sites/default/files/application_note_power_control_configuration.pdf).
- **Limit:** The inverter maximum output power
- **Country:** The selected country and grid setting
- **Voltage (Vdc):** The DC input voltage
- **Temp** (°C or °F): The inverter heat sink temperature



## Site Status

The Site status screen shows the accumulated status of all inverters connected to a master inverter in a chain (bus) and the master inverter status.

solar <b>edge</b>		
Status		
Site		
Production	Limit	Inverters
90 kW	1.00 MW	10/10
Inverter		
SN 07318000C		
Power	Voltage	Frequency
100 kW	277 Vac	60.9 Hz
<b>P_OK: 31 Of 31</b> Optimizers Connected	<b>S_OK</b> Server Connected	
<b>Status</b> Production	 <b>Switch</b> OFF	
CosPhi	Limit	Country
1.00	Export	USA2
 Switch Off. Production disabled >		
<b>Commissioning</b> >		

-  **Site status:**
-  **Production:** The AC output power
-  **Limit:** Limitation setting (Export or Production)
-  **Inverters:** Number of connected inverters in the cluster, including the master

## Communication Status

This screen displays the status of connection option(s): LAN, RS485, cellular or ZigBee Plug-in.

Communication		
LAN Connected	RS485-1 Modbus 2 of 2	RS485-2 SE Slave None
Cellular N/A		ZigBee NC

For each communication option, one of the following statuses is displayed:

- **Connected:** The inverter established a successful connection and communication with the specified server port
- **NC:** Not Connected
- **S\_OK:** The connection to the monitoring platform is successful (should appear only if the is connected to the server)
- **N/A :** Not Applicable
- **x of y:** Number of devices connected out of all devices
- Temporarily displayed (with a ⌚ clock sign):
  - **Initializing communication**
  - **Connecting** to a network
  - **Connecting** to SolarEdge servers
- **Error message** (with the ⚠ sign)

## Inverter Energy Status

Displays the total energy produced during the last day, month, year and since inverter installation.

Inverter Energy		
Today	This Month	This Year
45 kWh	1.14 MWh	13.68 MWh
Total: 41.03 MWh		

- **Today:** Since midnight
- **This Month:** Since 1st of the current month
- **This Year:** Since January 1st
- **Total (Wh):** The inverter total energy. If an external meter is installed, the value displayed in this line depends on the meter type connected to the inverter and its location:
  - If a bidirectional meter is connected at the consumption point, this value is the consumed energy.
  - If the meter is installed at the production point, this value is the energy produced by the site.
  - If the meter is installed at the grid connection point, this value is the energy exported to the grid.

## Meter Status

Meters	
<b>Production Meter</b>	
SN: XXXXXXXX	
<b>RS485-2</b> Modbus ID #2	<b>Status</b> OK
<b>Power</b> 7.60 kW	<b>Energy</b> 13.68MWh
<b>Export Meter</b>	
SN: XXXXXXXX	
<b>GPIO S0 meter</b> 1000 pulses per kWh	
<b>Power</b> 7.60 kW	<b>Energy</b> 13.68MWh
<b>Commissioning</b> >	

- **Type and function:** Displays the meter functionality (Production, Export, Import, Export+Import).
- **Status:** Displays OK if the meter is communicating with the inverter.
- **<Error message>:** If there is a meter error, it is displayed in this line.
- **Power:** Depending on the meter type connected to the inverter, this line displays the exported or imported power.
- **Energy:** The total energy read by the meter. The value displayed in this line depends on the meter type connected to the inverter and its location:
  - If a bidirectional meter is connected at the consumption point, this value is the consumed energy.
  - If the meter is installed at the production connection point, this value is the energy produced by the site.
  - If the meter is installed at the grid connection point, this value is the energy exported to the grid.



**NOTE**

This data is accumulated according to an internal real-time clock.

## EV Charging Status

When the EV charger is activated, this screen displays the EV charging status , according to the charging mode.

 <b>Status</b>		
<b>Inverter Energy</b>		
<b>Today</b> 45 kWh	<b>This Month</b> 1.14 Wh	<b>This Year</b> 13.68 Wh
Total 41.03 MWh		
<b>EV Charger</b>		
<b>Car</b> Charging	<b>Charger</b> 3.81 kW	
Energy Added 163 Wh		

- **EV / Car Status:** Connected / Disconnected / Charging
- **Charger:** Charging power x.xkW / Ready / Initializing
- **Energy Added:** 0 - 999 kWh added to the EV battery.  
After disconnecting the EV charger the last charged energy is displayed.

## Reporting and Monitoring Installation Data

**NOTE**



Monitoring the site requires connecting the inverter to the monitoring platform, using any of the wired or wireless options available from SolarEdge. Refer to *Setting Up Communication to the Monitoring Platform* on page 58.

## The Monitoring Platform

The monitoring platform provides enhanced PV performance monitoring and yield assurance through immediate fault detection and alerts at the module, string and system level.



Using the platform, you can:

- View the latest performance of specific components.
- Find under-performing components, such as modules, by comparing their performance to that of other components of the same type.
- Pinpoint the location of alerted components using the physical layout.

The monitoring platform enables accessing site information, including up-to-date information viewed in a physical or logical view:

- **Logical Layout:** Shows a schematic tree-layout of the components in the system, such as: inverters, strings, modules, meters and sensors, as well as their electrical connectivity. This view enables you to see which modules are connected in each string, which strings are connected to each inverter, and so on.
- **Physical Layout:** Provides a bird's eye view of the actual placement of modules in the site, and allows pinpoint issues to the exact location of each module on a virtual site map.

If you do not report the mapping of the installed power optimizers, the monitoring platform will show the logical layout indicating which power optimizers are connected to which inverter, but will not show strings or the physical location of power optimizers.

The monitoring platform includes a built-in help system, that guides you through the monitoring functionality.

For more information, refer to <https://www.solaredge.com/products/pv-monitoring#/>.



## Creating Logical and Physical Layout using Installation Information

To display a logical layout, insert the inverter serial number in the new site created in the monitoring platform. When the communication between the inverter and the monitoring server is established, the logical layout is displayed.

To display a physical layout, you need to map the locations of the installed power optimizers. To map the locations, use one of the methods described in the next sections.

### Designer

Designer recommends inverter and power optimizer selection per site size and enables report generation. You can create a project in Designer and export the site design with the string layout to the monitoring platform.

For more information, refer to

<https://www.solaredge.com/products/installer-tools/designer#/>.



## Mapper Application

Use the Mapper smart phone application to scan the power optimizer and inverter 2D bar-codes and create a virtual map of a PV site for enhanced monitoring and easier maintenance.

The Mapper application is integrated with the monitoring platform and enables:

- Simple on-site registration of new systems.
- Creating, editing and verifying system physical layout.
- Scanning and assigning the power optimizer serial number to the correct module in the system physical layout.

For detailed information, refer to the *Mapper* demo movies:

■ [Creating new sites using the Mapper mobile application](#)



■ [Mapping existing sites using the Mapper mobile application](#)



## Physical Layout Editor

1. If you are a registered installer, access the monitoring platform site creation page at <https://monitoring.solaredge.com/solaredge-web/p/home#createSites>. If you have not yet signed up, go to <https://monitoring.solaredge.com/solaredge-web/p/createSelfNewInstaller>.
2. Fill out all required information in the screen, which includes information about your installation, as well as details about its logical and physical mapping.



## Using a Paper Template

Fill out the Physical Layout Template (downloadable from the SolarEdge website <http://www.solaredge.com/files/pdfs/physical-layout-template.pdf>) using the detachable 2D barcode stickers on each power optimizer. Once the form is completed, use the Mapper to scan the 2D codes and create the map in the monitoring platform. Optionally, you can send the sticker sheet to SolarEdge Support for physical layout creation.



# Chapter 5: Setting Up Communication to the Monitoring Platform

The inverter sends the following information to the monitoring platform:

- Power optimizer information received via the DC power lines (the PV output circuit)
- Inverter information
- Information of any other connected devices

This chapter describes how to set up communication between:

- The inverter and the monitoring platform through the Internet (wired/ wireless), or through a cellular connection
- Multiple inverters for a master/slave configuration

Communication setup is not required for power harvesting, however it is needed for using the monitoring platform.

## CAUTION!

 When connecting the communication cables, make sure that the ON/OFF switch on the Connection Unit with Safety Switch is turned OFF, and the AC is turned OFF.

When configuring the communication parameters, make sure that the ON/OFF switch on the Connection Unit with Safety Switch is OFF, and the AC is turned ON.

## ATTENTION!

*Lors de la connexion des câbles de communication, assurez-vous que l'interrupteur MARCHE/ARRÊT à la base de l'onduleur soit en position ARRÊT, et le CA est en position ARRÊT. Lors de la configuration des paramètres de communication, assurez-vous que l'interrupteur MARCHE/ARRÊT soit en position ARRÊT, et le CA est en position MARCHE.*

## Communication Options

The following types of communication can be used to transfer the monitored information from the inverter to the monitoring platform.

Only communication products offered by SolarEdge are supported.

### Ethernet

Ethernet is used for a LAN connection. For connection instructions refer to *Creating an Ethernet (LAN) Connection* on page 63

## RS485

The following RS485 ports are available:

- RS485-1: Connects to the internal EV Charger circuit and (optionally) to a built-in Revenue Grade Meter (RGM). For connecting an external meter to inverters with or without a Built-in Revenue Grade Meter (RGM) see *Connecting an External Meter to an Inverter* on page 83.
- RS485-2: Enables connection of multiple SolarEdge devices and of non-SolarEdge devices over the same bus.

For connection instructions refer to *Creating an RS485 Bus Connection* on page 66

## Cellular

This wireless communication option (purchased separately) enables using a cellular connection to connect one or several devices (depending on the data plan used) to the monitoring platform.



The Cellular Plug-in is provided with a user manual, which should be reviewed prior to connection. Refer to

<https://www.solaredge.com/sites/default/files/cellular-plug-in-for-setapp-installation-guide.pdf>

## ZigBee

This option enables wireless connection of one or several devices to a ZigBee Gateway, for wireless communication to the monitoring platform.

The ZigBee Gateway is provided with an installation guide, which should be reviewed prior to connection. Refer to

<https://www.solaredge.com/sites/default/files/se-zigbee-gateway-for-setapp-installation-guide.pdf> .



## Communication Connectors

A communication gland with multiple openings is used for connection of the various communication options. The table below describes the functionality of each gland opening. Unused openings should remain sealed.

Opening for cable size (diameter)	Connection type
2.5 - 5 mm	RS485
4.5 - 7 mm, with cut	Ethernet (CAT5/6)
2 - 4 mm, with cut	Antenna cable for wireless communication

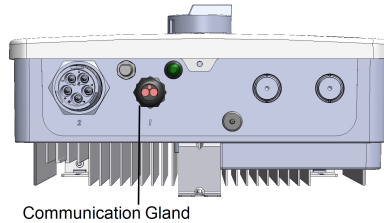

Figure 20: Communication Gland

The communication board has a standard RJ45 terminal block for Ethernet connection, a 6-pin terminal block for RS485 connection, and an 8-pin connector for power control devices.

The Cellular Plug-in can be connected to the communication board for optional wireless connection.

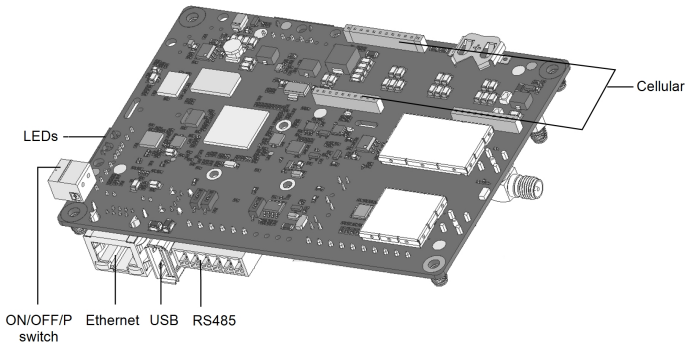

Figure 21: Communication board connectors

## Removing the Inverter Cover

1. Switch the inverter ON/OFF/P switch to OFF. Wait 5 minutes for the capacitors to discharge.
2. Turn the Safety Switch (if applicable) to OFF.
3. Disconnect the AC to the inverter by turning OFF the circuit breakers on the distribution panel.
4. Open the Allen screws of the inverter cover and carefully pull the cover horizontally before lowering it.
5. Open the inverter cover (see *Figure 22*).

### CAUTION!

When removing the inverter cover, make sure not to damage the internal components. SolarEdge will not be held responsible for any components damaged as a result of incautious cover removal.



### ATTENTION!

*Lors du retrait du couvercle, assurez-vous de ne pas endommager les composants internes. SolarEdge ne peut être tenue pour responsable des composants endommagés à la suite d'une imprudence dans le retrait du couvercle.*

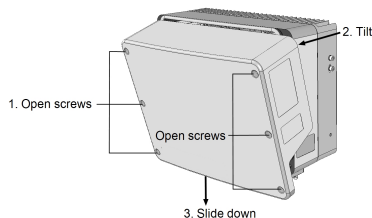

Figure 22: Removing the inverter cover

## Removing the Connection Unit with Safety Switch Cover

1. Turn OFF the AC breaker of the distribution panel and the safety switch (if applicable).
2. Open the Connection Unit with Safety Switch cover: Release the four Allen screws and remove the cover.

**CAUTION!**

When removing the Connection Unit with Safety Switch cover, make sure not to damage the internal components. SolarEdge will not be held responsible for any components damaged as a result of incautious cover removal.



**ATTENTION!**

*Lors du retrait du couvercle, assurez-vous de ne pas endommager les composants internes. SolarEdge ne peut être tenue pour responsable des composants endommagés à la suite d'une imprudence dans le retrait du couvercle.*

## Creating an Ethernet (LAN) Connection

This communication option enables using an Ethernet connection to connect the inverter to the monitoring platform through a LAN.

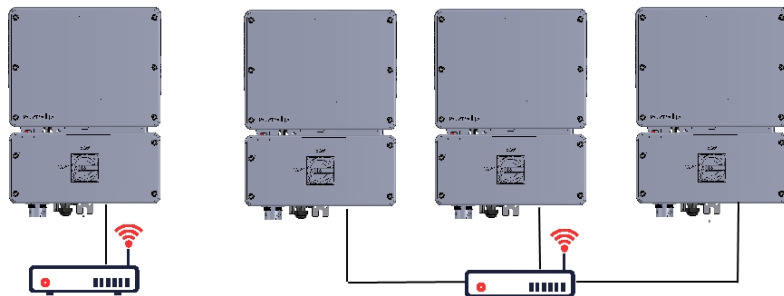

Figure 23: Example of Ethernet connection

Ethernet cable specifications:

- Cable type – a shielded Ethernet cable (Cat5/5E STP) may be used
- Maximum distance between the inverter and the router – 100 m/ 330 ft.

### NOTE



If using a cable longer than 10 m / 33 ft in areas where there is a risk of induced voltage surges by lightning, it is recommended to use external surge protection devices.

For details refer to:

[https://www.solaredge.com/sites/default/files/overvoltage\\_surge\\_protection\\_na.pdf](https://www.solaredge.com/sites/default/files/overvoltage_surge_protection_na.pdf).



→ To connect the Ethernet cable:

1. Remove the inverter and Connection Unit with Safety Switch covers as described in *Removing the Inverter Cover* on page 61.
2. Open the communication gland #1.

### CAUTION!

The gland includes a rubber waterproof fitting, which should be used to ensure proper sealing.



### ATTENTION!

*Le cote interne du gland contient une rondelle qui doit être utilisée pour une bonne étanchéité.*



3. Remove the plastic seal from one of the large openings.
4. Remove the rubber fitting from the gland and insert the CAT5/6 cable through the gland and through the gland opening in the inverter.
5. Insert the cable through the opening in the Connection Unit with Safety Switch towards the communication board.
6. Push the cable into the cut opening of the rubber fitting.

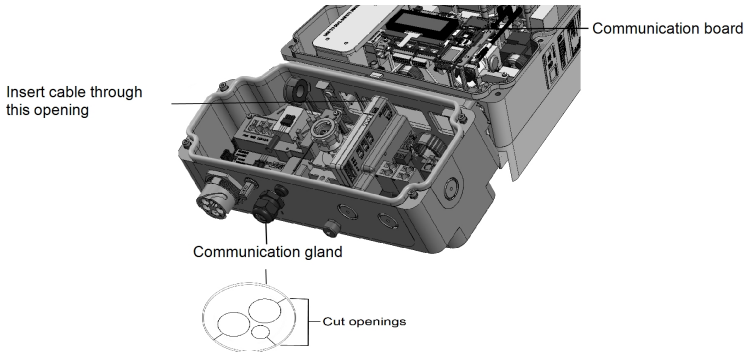

Figure 24: Communication glands and rubber fitting

CAT5/6 standard cables have eight wires (four twisted pairs), as shown in the diagram below. Wire colors may differ from one cable to another. You can use either wiring standard, as long as both sides of the cable have the same pin-out and color-coding.

RJ45 Pin #	Wire Color <sup>(1)</sup>		10Base-T Signal 100Base-TX Signal
	T568B	T568A	
1	White/Orange	White/Green	Transmit+
2	Orange	Green	Transmit-

<sup>(1)</sup>The inverter connection does not support RX/TX polarity change. Supporting crossover Ethernet cables depends on the switch capabilities.

RJ45 Pin #	Wire Color <sup>(1)</sup>		10Base-T Signal 100Base-TX Signal
	T568B	T568A	
3	White/Green	White/Orange	Receive+
4	Blue	Blue	Reserved
5	White/Blue	White/Blue	Reserved
6	Green	Orange	Received-
7	White/Brown	White/Brown	Reserved
8	Brown	Brown	Reserved

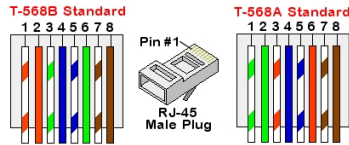

Figure 25: Standard cable wiring

7. Use a pre-terminated cable to connect via gland #1 to the RJ45 plug on the inverter's communication board or, if using a spool of cable, connect as follows:
  - a. Insert the cable through the gland.
  - b. Remove the cable's external insulation using a crimping tool or cable cutter and expose eight wires.
  - c. Insert the eight wires into an RJ45 connector, as described in *Figure 25*
  - d. Use a crimping tool to crimp the connector.
  - e. Connect the Ethernet connector to the RJ45 port on the communication board.

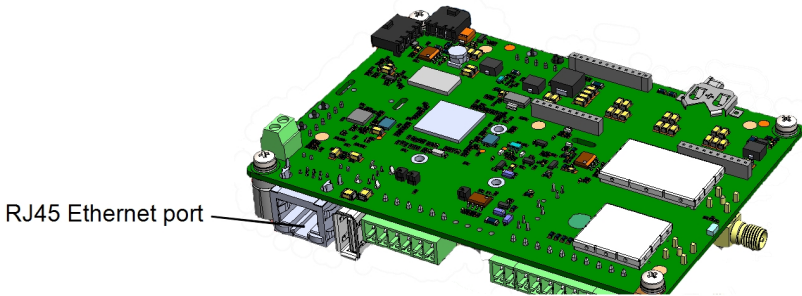

Figure 26: The RJ45 Ethernet connection

<sup>(1)</sup>The inverter connection does not support RX/TX polarity change. Supporting crossover Ethernet cables depends on the switch capabilities.

8. For the switch/router side, use a pre-crimped cable or use a crimper to prepare an RJ45 communication connector: Insert the eight wires into the RJ45 connector in the same order as above (*Figure 25*).
9. Connect the cable RJ45 connector to the RJ45 port of the Ethernet switch or router. You can connect more than one inverter to the same switch/router or to different switches/routers, as needed. Each inverter sends its monitored data independently to the SolarEdge monitoring platform.
10. The inverter is configured by default to LAN. If reconfiguration is required:
  - a. Make sure the ON/OFF/P switch is OFF.
  - b. Turn ON the AC to the inverter by turning ON the circuit breaker on the main distribution panel.
  - c. Turn ON the Connection Unit with Safety Switch.

**WARNING!**

ELECTRICAL SHOCK HAZARD. Do not touch uninsulated wires when the inverter cover is removed.

**AVERTISSEMENT!**

*RISQUE D'ÉLECTROCUTION, ne touchez pas les fils non isolés lorsque le couvercle de l'onduleur est retiré.*

- d. Configure the connection as described in *Communication* on page 45.

**NOTE**

If your network has a firewall, you may need to configure it to enable the connection to the following address:

- Destination Address: prod.solaredge.com
- TCP Port: 22222 (for incoming and outgoing data)

11. Verify the connection, as described in *Verifying the Connection* on page 68.

## Creating an RS485 Bus Connection

The RS485 option enables creating a bus of connected inverters, consisting of up to 31 slave inverters and 1 master inverter. Using this option, inverters are connected to each other in a bus (chain), via their RS485 connectors. The first and last inverters in the chain must be terminated as described on page 66.

RS485 wiring specifications:

- Cable type: Min. 3-wire shielded twisted pair (a shielded Ethernet cable (Cat5/5E STP) may be used)
- Wire cross-section area: 0.2- 1 mm<sup>2</sup>/ 24-18 AWG (a CAT5 cable may be used)
- Maximum nodes: 32
- Maximum distance between first and last devices: 1 km /3300 ft.

**NOTE**

If using a cable longer than 10 m/ 33 ft in areas where there is a risk of induced voltage surges by lightning, it is recommend to use external surge protection devices. For details refer to: [https://www.solaredge.com/sites/default/files/overvoltage\\_surge\\_protection\\_na.pdf](https://www.solaredge.com/sites/default/files/overvoltage_surge_protection_na.pdf).



If grounded metal conduit are used for routing the communication wires, a lightning protection device is not required.

If not using surge protection, connect the grounding wire to the first inverter in the RS485 chain; make sure the grounding wire is not in contact with other wires. Connect the grounding wire to the grounding bus-bar in the Connection Unit with Safety Switch.

→ **To connect to the monitoring platform:**

1. Designate a single inverter as the connection point between the RS485 bus and the monitoring platform. This inverter will serve as the master inverter.
2. Connect the master to the monitoring platform via the LAN option (refer to *Creating an Ethernet (LAN) Connection* on page 63) or any of the other options.

→ **To configure the RS485 bus:**

All inverters are configured by default as slaves. To configure the master:

1. Verify the ON/OFF/P switch is OFF.
2. Verify that AC is on.
3. Use SetApp to access the **Commissioning** menu screen as described in *Communication* on page 45.
4. From the **Commissioning** menu tap **Communication**. The Communication screen is displayed.
5. Select the following to configure the connection:

- Server → LAN, Cellular or Wi-Fi
- RS485-2 → Protocol → SolarEdge → **SolarEdge Master**
- RS485-2 → **Slave Detect**

The system starts automatic detection of the slave inverters connected to the master inverter. The inverter should report the correct number of slaves. If it does not, verify the connections and terminations.

6. To check the slave IDs and last communication time, select **RS4852** → **Slave List**.
7. Verify the connection of the master to the monitoring platform, as described in the next section.

## Verifying the Connection

After connecting and configuring a communication option, perform the following steps to check that the connection to the monitoring server has been successfully established.

1. Access the Status screen:
  - a. If not already ON - turn ON AC to the inverter by turning ON the circuit breaker on the main distribution panel.
  - b. Open SetApp and follow the instructions on the screen (scan the inverter barcode; move the ON/OFF/P switch to P position (for less than 5 sec) and release). The mobile device creates a Wi-Fi connection with the inverter and displays the main Commissioning screen.

 <b>Status</b>		
<b>Inverter</b> SN 07318000C		
<b>Power</b>	<b>Voltage</b>	<b>Frequency</b>
Optimizers Connected		S_OK Server Connected
<b>Status</b> Production		<b>Switch</b> ON
<b>CosPhi</b> 1.00	<b>Limit</b> No Limit	<b>Country</b> USA2
<b>Voltage</b>	<b>Temp</b>	<b>Fan</b>
<b>Commissioning</b>		

2. Check that **S\_OK - Server Connected** status appears in the main inverter section.
3. Scroll down to the Communication section and check that the communication options are as required. For more information refer to *Communication Status* on page 52.

<b>Communication</b>		
<b>LAN</b> Connected	<b>RS485-1</b> Modbus 2 of 2	<b>RS485-2</b> SE Slave None
<b>Cellular</b> N/A		<b>ZigBee</b> NC

## Chapter 5: Errors and Troubleshooting

This appendix describes general system problems, and how to troubleshoot them. For further assistance, contact SolarEdge Support.

### Identifying Errors

Errors may be indicated in various system interfaces: On the inverter bottom panel, a red LED indicates an error. In the monitoring platform and SetApp, errors are displayed with codes. For more information on the codes displayed for error and warning messages, refer to

[https://www.solaredge.com/sites/default/files/troubleshooting\\_for\\_se\\_inverter\\_insallation\\_guide\\_addendum\\_na.pdf](https://www.solaredge.com/sites/default/files/troubleshooting_for_se_inverter_insallation_guide_addendum_na.pdf). This document describes errors that appear in SetApp, monitoring platform, and LCD (for inverters with LCD). To identify the error types, use the methods described below.



→ To identify the error type using the inverter LEDs:

1. Move the ON/OFF/P switch to **P** position for **less** than 5 seconds and release it.
2. Observe the LED lights and use the following table to identify the error type. For more information, refer to <https://www.solaredge.com/us/leds>.



Error type	LED color and state		
	Red	Green	Blue
Arc detected	ON	OFF	OFF
Isolation or RCD problem	Blinking	OFF	OFF
Grid error	OFF	ON	OFF
High temperature	OFF	Blinking	OFF
Pairing failed	OFF	OFF	ON
Other issue	OFF	OFF	Blinking

→ To identify the error type using the monitoring platform:

1. Open the site dashboard and click the **Layout** icon.
2. Right-click the inverter and select **Info** from the menu. The inverter details window is displayed.
3. Click the **Errors** tab. The list is displayed.

## EV Charger-related Troubleshooting

For the following system errors, when an error occurs, the red LED lights ON and the buzzer beeps 10 times.

The error message is displayed on the SolarEdge mobile app screen.

If the error persists- contact SolarEdge Support.

Error code	Displayed Error message	Description and Troubleshooting
3x85	EVSE Comm. Error	An internal communication error. When this error occurs, the red LED is not lit, the buzzer does not beep and charging is not affected. Check that the internal connections on the communication board are properly done.
1Cx1; 1Cx8	Over Current Press Charge Now	EV Charger AC over current. <ul style="list-style-type: none"> <li>• Press the Charge Now pushbutton on the Connection Unit with Safety Switch, see <i>Figure 10</i></li> <li>-or-</li> <li>• Tap Charge Now on the EV Charger tab of the Monitoring App</li> </ul>
1Cx2; 1xC9	Over Voltage Press Charge Now	EV Charger AC voltage too high. <ul style="list-style-type: none"> <li>• Press the Charge Now pushbutton on the Connection Unit with Safety Switch, see <i>Figure 10</i></li> <li>-or-</li> <li>• Tap Charge Now on the EV Charger tab of the Monitoring App</li> </ul>
1Cx3,Cx14; 1Cx15	Ground Fault (RCD) Press Charge Now	EV Charger ground fault detected. <ul style="list-style-type: none"> <li>• Press the Charge Now</li> </ul>



Error code	Displayed Error message	Description and Troubleshooting
		<p>-or-</p> <ul style="list-style-type: none"> <li>• Tap Charge Now on the EV Charger tab of the Monitoring App</li> </ul>
1Cx4; 1Cx5; 1Cx12 -1Cx13	Internal Error Disconnect from EV	<p>Internal error.</p> <ul style="list-style-type: none"> <li>• Disconnect the EV Charger cable from the vehicle.</li> <li>• Turn the inverter AC circuit breaker OFF and ON.</li> <li>• Reconnect the EV Charger Cable to the vehicle</li> </ul>
1CxB/D; 1Cx10 - 1Cx11	Interface Error (Pilot) Press Press Charge Now	<ul style="list-style-type: none"> <li>• Press the Charge Now pushbutton on the Connection Unit with Safety Switch, see <i>Figure 10</i></li> </ul> <p>-or-</p> <ul style="list-style-type: none"> <li>• Tap Charge Now on the EV Charger tab of the Monitoring App</li> </ul>
1Cx6	Ground Disconnected Disconnect from EV	<p>Ground Disconnected.</p> <ul style="list-style-type: none"> <li>• Disconnect the EV Charger cable from the vehicle.</li> <li>• Contact SolarEdge Support.</li> </ul>
1Cx7	Over Temperature	<p>EV Charger over temperature</p> <p>Verify proper clearances around the inverter and EV Charger Cable.</p> <p>After verification reconnect the EV charger cable to the EV.</p>
1CxA	Under Voltage Press Charge Now	<p>EV Charger AC voltage too low.</p> <ul style="list-style-type: none"> <li>• Press the Charge Now pushbutton on the Connection</li> </ul>

Error code	Displayed Error message	Description and Troubleshooting
		-or- <ul style="list-style-type: none"> <li>• Tap Charge Now on the EV Charger tab of the Monitoring App</li> </ul>
1CxC	Vent not supported Disconnect from EV	The SolarEdge EV charger does not charge vehicles that require ventilation while charging. If this error occurs, the vehicle cannot be charged.
1CxE;1CxF	Charging retries ended Disconnect from EV	Charging retries ended <ul style="list-style-type: none"> <li>• Disconnect the EV Charger cable from the vehicle.</li> <li>• Contact SolarEdge Support.</li> </ul>

## Power Optimizer Troubleshooting

Problem	Possible Cause and Troubleshooting
Pairing failed	<p>Power optimizers are shaded.</p> <p>If you connected the inverter to the monitoring platform, retry pairing remotely (during sunlight). Make sure to leave the inverter ON/OFF/P switch ON and that S_OK appears in the status screen.</p>
String voltage is 0V	<p>Power optimizer (s) output is disconnected.</p> <p>Connect all power optimizer outputs.</p>
String voltage not 0V but lower than number of optimizers	<p>Power optimizer(s) not connected in the string.</p> <p>Connect all power optimizers.</p>
	<p>Module(s) not connected properly to power optimizer inputs (not applicable to smart modules).</p> <p>Connect the modules to the optimizer inputs.</p>
	<p>String reverse polarity.</p> <p>Check string polarity using a voltmeter and correct if needed.</p>

Problem	Possible Cause and Troubleshooting
<p data-bbox="101 403 490 464">String voltage is higher than number of optimizers</p> <div data-bbox="176 480 490 683" style="border: 1px solid black; padding: 5px;"> <p data-bbox="176 480 295 504"><b>WARNING!</b></p> <p data-bbox="176 512 490 683">If the measured voltage is too high, the installation may not have a safe low voltage. PROCEED WITH CARE! A deviation of <math>\pm 1\%</math> per string is reasonable.</p> </div> <div data-bbox="113 671 490 914" style="border: 1px solid black; padding: 5px;">  <p data-bbox="176 691 490 914"><i>Si la tension mesurée est trop haute, la tension basse de sécurité pourrait manquer dans l'installation. REDOUBLEZ DE PRECAUTION. Une déviation de <math>\pm 1\%</math> par string est raisonnable.</i></p> </div>	<p data-bbox="490 193 1003 253">Extra power optimizer(s) connected in the string (not applicable to smart modules).</p> <p data-bbox="490 264 1003 325">Check if an extra power optimizer is connected in the string. If not – proceed to next solution.</p> <p data-bbox="490 336 1003 429">A module is connected directly to the string, without a power optimizer (not applicable to smart modules).</p> <p data-bbox="490 440 1003 576">Verify that only power optimizers are connected in the string and that no module outputs are connected without a power optimizer. If the problem persists, proceed to the next step.</p> <p data-bbox="490 587 1003 611">Power optimizer(s) malfunction.</p> <ol data-bbox="490 622 1003 1128" style="list-style-type: none"> <li data-bbox="490 622 1003 687">1. Disconnect the wires connecting the power optimizers in the string.</li> <li data-bbox="490 699 1003 914">2. Measure the output voltage of each power optimizer to locate the power optimizer that does not output 1V safety voltage. If a malfunctioning power optimizer is located, check its connections, polarity, module, and voltage.</li> <li data-bbox="490 925 1003 1128">3. Contact SolarEdge Support. Do not continue before finding the problem and replacing the malfunctioning power optimizer. If a malfunction cannot be bypassed or resolved, skip the malfunctioning power optimizer, thus connecting a shorter string.</li> </ol>

# Mechanical Specifications

The following figure provides inverter dimensions in mm [in].

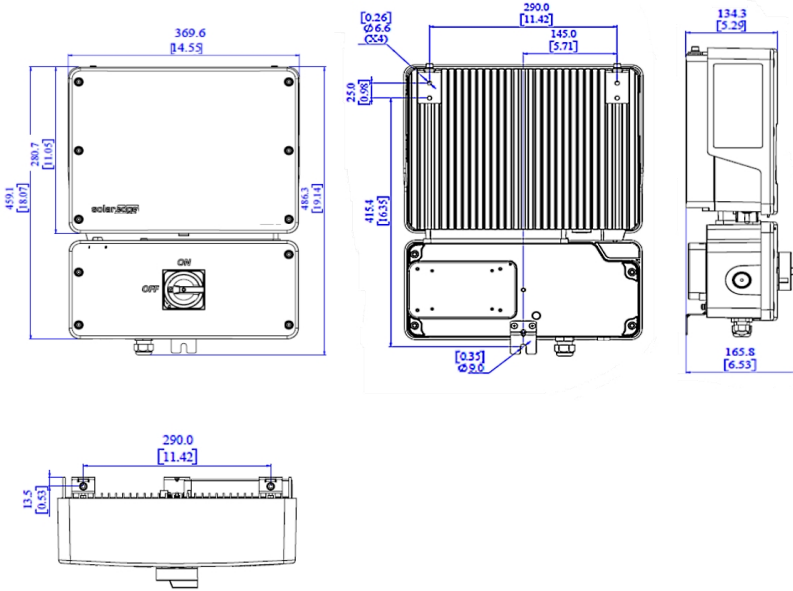

Figure 27: Inverter dimensions

# Appendix A: Replacing and Adding System Components



## NOTE

If you are permanently disassembling the installation or part of it, make sure to use the disposal methods dictated by local regulations.

## Fuse Replacement

The inverter is equipped with a fuse, located at the top right corner of the inverter. Fuse replacement kits are available from SolarEdge or you can use other fuses with identical ratings.

1. Turn OFF the inverter ON/OFF/P switch, and wait until the green LED is blinking, indicating that the DC voltage is safe (<50V), or wait five minutes before continuing to the next step.
1. Turn OFF the Connection Unit with Safety Switch.
2. Open and remove the inverter cover.
3. Remove the existing fuse from the upper corner of the inverter and replace with a new fuse.
4. Close the inverter cover.

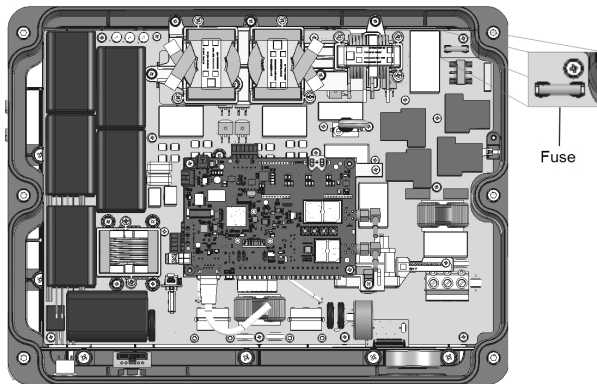

Figure 28: Inverter fuse

5. Turn ON:
  - The inverter ON/OFF/P switch

### ■ The Connection Unit with Safety Switch

6. Verify proper system operation.

## Replacing an Inverter

1. Turn OFF the inverter ON/OFF/P switch, and wait until the green LED is blinking , indicating that the DC voltage is safe (<50V), or wait five minutes before continuing to the next step.
2. Turn OFF the Connection Unit with Safety Switch.
3. Disconnect the AC to the inverter by turning OFF the AC circuit breaker of the distribution panel.
4. Open the Connection Unit with Safety Switch cover: Release the four Allen screws and remove the cover.
5. Open the inverter cover as described in *Removing the Inverter Cover* on page 61.
6. Disconnect the DC and AC cables from the Connection Unit with Safety Switch.

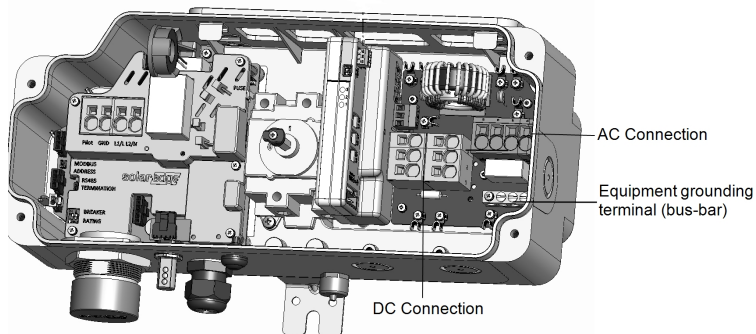

Figure 29: DC and AC connections

7. Disconnect the wires connected between the inverter and the Connection Unit with Safety Switch:
  - Antenna cable from the communication board
  - RS485 connection from the communication board
  - DC and AC wires in the Connection Unit with Safety Switch
  - Grounding cable
8. Disconnect the Connection Unit with Safety Switch from the inverter by opening the two clips securing the Connection Unit with Safety Switch to the inverter: Carefully place a screwdriver between the clip and the enclosure and pull the clip.

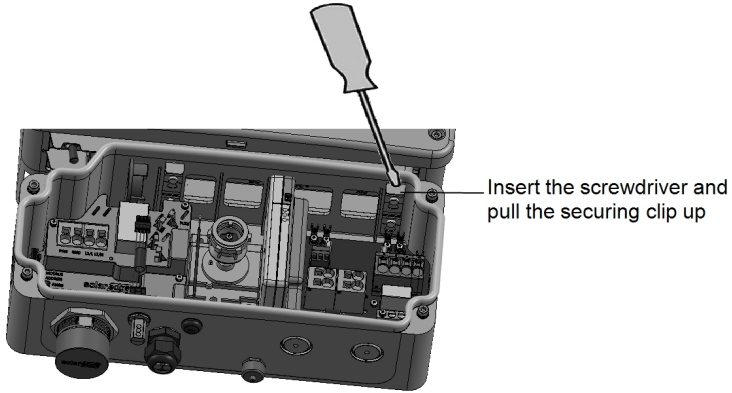

Figure 30: Disconnecting the Connection Unit with Safety Switch from the inverter

9. Remove the screws securing the inverter to the mounting brackets and lift the inverter from the mounting bracket.

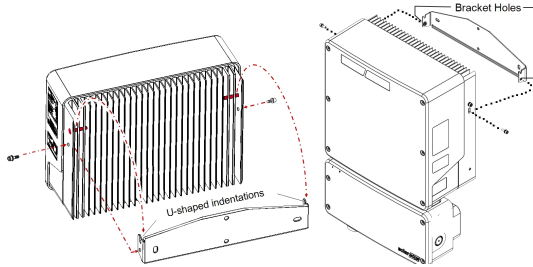

Figure 31: Mounting brackets



**NOTE**

If you remove the old inverter and do not immediately install a new one, then:



- Lock the Connection Unit with Safety Switch in the OFF position using a lock on the switch.
- Secure the Connection Unit with Safety Switch bracket to the wall/pole, using 3 screws
- Use insulation tape to isolate each of the AC and DC wires.
- Seal the open conduits using duct tape.
- Install the Connection Unit with Safety Switch sealing cover supplied with the inverter and secure with retaining clips.

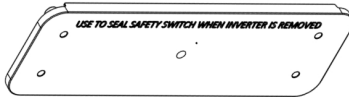

10. Place the new inverter on the mounting brackets and secure it using the screws.
11. Insert the wires from the Connection Unit with Safety Switch into the openings in the inverter and the ferrite bead.
12. Fasten the two clips securing the Connection Unit with Safety Switch to the inverter.
13. Reconnect the cables: Follow the instructions of *Installing the Inverter* on page 30.
14. Close the inverter and Connection Unit with Safety Switch covers.
15. Perform the commissioning steps as described in *Activating, Commissioning and Configuring the System* on page 42.

## Replacing the Connection Unit with Safety Switch

1. Turn OFF the inverter ON/OFF/P switch, and wait until the green LED is blinking , indicating that the DC voltage is safe (<50V), or wait five minutes before continuing to the next step.
2. Turn OFF the AC breaker of the distribution panel and the Connection Unit with Safety Switch .
3. Open the Connection Unit with Safety Switch cover: Release the four Allen screws and remove the cover.
4. Open the inverter cover as described in *Removing the Inverter Cover* on page 61.

5. Disconnect the DC wires from the inverter and the AC wires from the Connection Unit with Safety Switch.
6. Disconnect the wires connected between the inverter and the Connection Unit with Safety Switch:
  - Antenna cable from the communication board
  - RS485 and/or Ethernet connection from the communication board
  - Grounding cable
7. Open the Connection Unit with Safety Switch bracket screws.

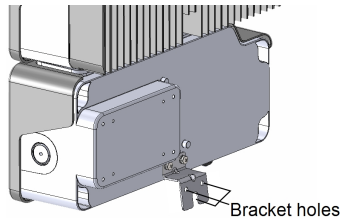

Figure 32: Connection Unit with Safety Switch bracket

8. Disconnect the Connection Unit with Safety Switch from the inverter by opening the two clips securing the Connection Unit with Safety Switch to the inverter: Carefully place a screwdriver between the clip and the enclosure and pull the clip.

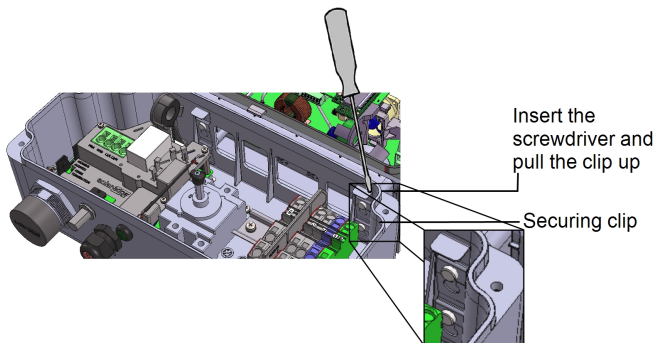

Figure 33: Disconnecting the Connection Unit with Safety Switch from the inverter

9. Detach the Connection Unit with Safety Switch from the inverter.
10. Place the new Connection Unit with Safety Switch and secure it to the inverter using the clips.

11. Insert the wires from the inverter into the openings in the Connection Unit with Safety Switch and the ferrite bead.
12. Reconnect the cables: Follow the instructions of *Installing the Inverter* on page 30.
13. Close the inverter cover.
14. Fasten the Connection Unit with Safety Switch bracket using a standard bolt.
15. Perform the commissioning steps as described in *Activating, Commissioning and Configuring the System* on page 42.

## Appendix B: Connecting an External Meter to an Inverter

This section provides instructions for connecting an external meter to inverters with or without a Built in Revenue Grade Meter (RGM).

### Connecting an External Meter to an Inverter

Remove the wires connected to the RS485-1 pins on the communication board (see figure below), and insert the external meter wires together with the original wires (two wires per pin). Ensure to maintain the original wire order.

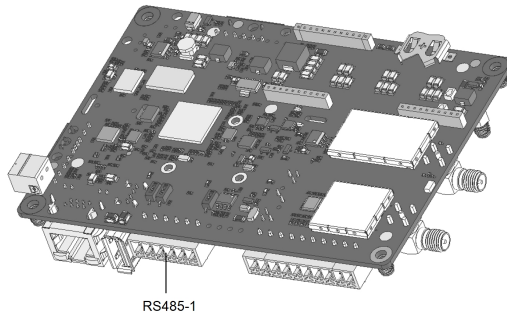

### Connecting an External Meter to an Inverter with a Built in Revenue Grade Meter (RGM)

Remove the wires connected to the RGM RS485-1 pins in the Connection Unit with Safety Switch (see figure below), and insert the external meter wires together with the original wires (two wires per pin). Ensure to maintain the original wire order.

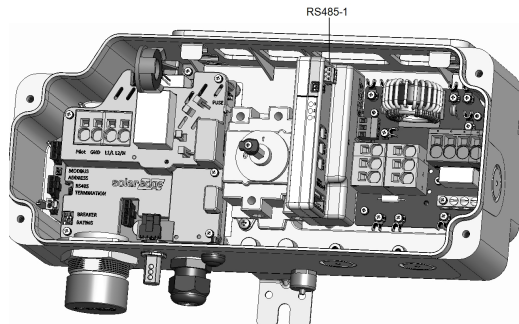

# Technical Specifications - EV Charging Single Phase Inverter (North America)

## Inverter Specifications

	SE3800H-US	SE5000H-US	SE6000H-US	SE7600H-US	SE11400H-US	Unit
<b>OUTPUT</b>						
Rated AC Power Output	3800	5000	6000	7600	11400	VA
Max AC Power Output	3800	5000	6000	7600	11400	VA
AC Output Voltage Min.-Nom.-Max.	211 - 240 - 264					Vac
Maximum Continuous Output Current	16	21	25	32	47.5	Aac
AC Frequency (Nominal)	59.3 - 60 - 60.5 <sup>(1)</sup>					Hz
Inrush current AC (Peak/ Duration)	2.8/20				3.45/20	Aac (rms) / ms
Maximum output overcurrent protection	35	48	55	80		A
Power factor range	1 (adjustable from -0.85 to +0.85)					
Total harmonic distortion	< 3%					
GFDI Threshold	1					A
Utility Monitoring, Islanding Protection, Country Configurable Thresholds	Yes					

(1)For other regional settings please contact SolarEdge support.

	SE3800H-US	SE5000H-US	SE6000H-US	SE7600H-US	SE11400H-US	Unit
<b>INPUT</b>						
Maximum DC Power	5900	7750	9300	11800	17650	W
Transformer-less, Ungrounded	Yes					
Maximum Input Voltage	480					Vdc
Nominal DC Input Voltage	380			400		Vdc
Maximum Input Current	10.5	13.5	16.5	20	30.5	Adc
Max. Input Short Circuit Current	45					Adc
Reverse-Polarity Protection	Yes					
Ground-Fault Isolation Detection	600 kΩ Sensitivity					
Maximum Inverter Efficiency	99.2					%
CEC Weighted Efficiency	99					%
Nighttime Power Consumption	< 2.5					W
<b>ADDITIONAL FEATURES</b>						
Supported Communication Interfaces	RS485, Ethernet, ZigBee (optional), Cellular (Optional)					
Revenue Grade Data, ANSI C12.20	Optional <sup>(1)</sup>					
Rapid Shutdown - NEC 2014 and 2017 690.12	Automatic Rapid Shutdown upon AC grid disconnect					

(1)Revenue grade inverter P/N: SExxxxH-US000xxW2.

	SE3800H- US	SE5000H- US	SE6000H- US	SE7600H- US	SE11400H- US	Unit
<b>STANDARD COMPLIANCE</b>						
Safety	UL1741, UL1741 SA, UL1699B, CSA C22.2, Canadian AFCI according to T.I.L. M-07					
Grid Connection Standards	IEEE1547, Rule 21, Rule14 (HI)					
Emissions	FCC part15 class B					
RoHS	Yes					
<b>INSTALLATION SPECIFICATIONS</b>						
AC output conduit size / AWG range	1" maximum/ 14-6 AWG				1" maximum/ 14-4 AWG	
DC input conduit size / # of strings / AWG range	1" maximum/ 1-2 strings / 14-6 AWG				1" maximum / 1-3 strings / 14-6 AWG	
Dimensions with Connection Unit with Safety Switch (HxWxD)	17.7 x 14.6 x 6.8 / 450 x 370 x 174				21.3 x 14.6 x 7.3 / 540 x 370 x 185	in/mm
Weight with Connection Unit with Safety Switch	22 / 10	25.1/11.4	26.2 / 11.9		38.8 / 17.6	lb / kg
Noise	< 25			< 50		dBA
Cooling	Natural Convection					
Operating Temperature Range,	-40 to +140 / -40 to +60 <sup>(1)</sup>					°F/ °C
Protection Rating	NEMA 4X (Inverter with Connection Unit with Safety Switch)					

## Default Trip Limits and Times According to IEEE1547

### NOTE



The inverters are equipped with adjustable utility protective function set-points, and can be aggregated above 30kW on a single Point of Common Connection. The default settings are in compliance with IEEE1547. Utility authorization is required to change these set-points.

(1) Full power up to at least 50°C/122°F. For power de-rating information refer to :

<https://www.solaredge.com/sites/default/files/se-temperature-derating-note-na.pdf>

Voltage Range (% of Base Voltage)	Maximum Clearing Time (Sec)
V < 50%	0.16
50 % < V < 88%	2.00
110% < V < 120%	1.00
V > 120 %	0.16
Frequency Range (Hz)	Maximum Clearing Time (Sec)
> 60.5	0.16
< 59.3 (Hawaii – 57)	0.16

## Recommended OCPD Size per Grid

Inverter	Maximum Output Current (A)	Minimum Fuse Rating (A)	Maximum Fuse Rating (A)
SE3800H-US	16	20	50
SE5000H-US	21	30	50
SE6000H-US	25	35	50
SE7600H-US	32	40	50
SE11400H-US	47.5	60	80

## EV Charger and EV Charger Cable Specifications

OUTPUT — AC		
Charging Level	AC Level 2	
	Connection to the SolarEdge monitoring platform is required for first EV charging	
Rated AC Power Output (Grid & PV)	9600	W
Nominal AC Output Voltage	240	Vac
Nominal AC Frequency	60	Hz
Maximum Continuous Output Current @240V (Grid & PV)	40	Aac
Ground Fault Detection Threshold	5	mA
ADDITIONAL FEATURES		
EV Charger Status LEDs, Fault Indicator	Yes	
EV Charger Unplugging Detection	Yes, current termination according to SAE J1772	



EV Charger Ground Connection Monitoring	Yes, continuous	
EV Charger Configuration	Via the monitoring app; Ethernet or ZigBee connection is required <sup>(1)</sup>	
<b>STANDARD COMPLIANCE</b>		
Safety	UL2594, UL2231-1, UL2231-2, NEC Article 625 compliant	
EV Charger	SAE J1772-2009	
<b>INSTALLATION SPECIFICATIONS</b>		
EV Charger Connector	SAE J1772-2009	
EV Charger Cable Length <sup>(2)</sup>	25 / 7.6	ft/ m
EV Charger Cable Weight	12.5 / 5.7	lb / kg
EV Charger and Cable Operating Temperature Range	-22 to +122 / -30 to +50	°F/ °C
Protection Rating (connected to EV or with dust cap)	NEMA 3R	

---

(1)Cellular connection may be used; requires a SIM card with a 1GB data plan that should be purchased from a cellular provider.

(2)EV Charger cable ordered separately.

If you have technical queries concerning our products, please contact our support through the SolarEdge service portal: [www.solaredge.com/service/support](http://www.solaredge.com/service/support)

US & Canada (+1)	(0) 510 498 3200
Worldwide (+972)	(0) 073 240 3118
Fax (+1)	(0) 530 273 2769
Email	<a href="mailto:ussupport@solaredge.com">ussupport@solaredge.com</a>